

STABILITY TEST ON CZ AND TRI-SILICON WAFERS WITH DIFFERENT SURFACE MORPHOLOGIES

D. Sontag, G. Hahn, A. Schneider
University of Konstanz, Department of Physics, PO Box X916, 78457 Konstanz, Germany
Tel: +49-7531-88-3644, Fax: +49-7531-88-3895. Email: giso.hahn@uni-konstanz.de

ABSTRACT: Tri-silicon has been developed to cope with the drastical increase in silicon solar cell production and the correlated bottleneck in solar grade material. First results revealed stabilities of up to 50% higher for Tri-silicon (Tri-Si) in comparison to CZ or multi-crystalline silicon (mc). To verify these results a stability test has been performed which confirms a higher maximum tensile strength for Tri-Si as compared to CZ, as long as there is no surface texturisation applied. After introducing an acidic surface texture the difference in tensile strengths for both materials vanishes. The maximum tensile strength is no longer determined by crystal orientation or grain boundaries in Tri-Si but dominated by surface damage introduced by the surface texturisation itself. Another material property of Tri-Si is its higher stiffness as compared to CZ. At a wafer thickness of 220 μm the maximum displacement for Tri-Si is only about 77% of the value for CZ. To compare the influence of different surface morphologies, additionally an alkaline texture is applied which reveals less negative influence on the tensile strength of a CZ wafer.

Keywords: c-Si - 1, Multi-Crystalline - 2, Texturisation - 3

1 INTRODUCTION

Ingot materials like CZ or mc-Si are responsible for about 50% of the module costs for wafer production. To overcome this problem alternative materials like Tri-Si have been developed which have the potential to reduce material losses and costs. First experiments published in literature concerning wafer stabilities of CZ and Tri-silicon reveal a higher stability for Tri-silicon [1]. As a result it would be possible to produce thinner wafers without losses in yield, and therefore less material would be wasted by sawing the wafers out of an ingot. Here the results of a stability test are presented which was performed not only to compare the stabilities of CZ and Tri-silicon wafers, but also to investigate the influence of different surface texturing techniques on wafer stability. Additionally, the effect of saw damage reduction on the wafer stability is examined.

2 EXPERIMENTAL SETUP

There are different possible setup geometries to perform a stability test. For this experiment we chose the twist geometry, which introduces a moderate but equally spread force to the edges of a wafer [2], therefore it is sensitive in the whole wafer area and not only in some areas where peak forces occur. A sketch of the chosen geometry is shown in Fig. 1. Two pins are supporting the wafer at the opposite corners in a distance of 13 cm while two other pins separated by the same distance are pressing the wafer downwards. The applied force is measured by a strain gauge and recorded together with the corresponding displacement.

In Fig. 2 a real picture of a breakage experiment is presented. It demonstrates the flexibility of a polish etched CZ wafer with a thickness of 260 μm . The picture was taken right before the wafer was breaking.

For this experiment 90 CZ and 70 Tri-Si wafers ($10 \cdot 10 \text{ cm}^2$) have been used. As every wafer has a slightly different thickness and as it was not possible to ensure neighbouring positions for all the wafers of one type of material, the wafers were sorted by thickness (300-340 μm) and divided into groups with 10 wafers each. Before the wafers were broken each group obtained a different surface treatment. Table I contains a summary

of the wafer thicknesses and surface morphologies after preparation. While group 1 was left untreated (as cut), groups 2-9 were etched with CP6 polishing etch. The resulting thickness of the wafers is dependent on the time they were exposed to the etching solution. For group 2-3 it is important to etch off only a certain amount of silicon

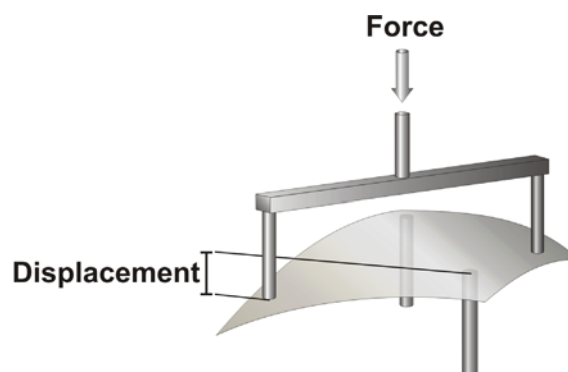

Figure 1: Twist geometry used for experiments presented in this paper. The maximum tensile strength and the maximum displacement are measured.

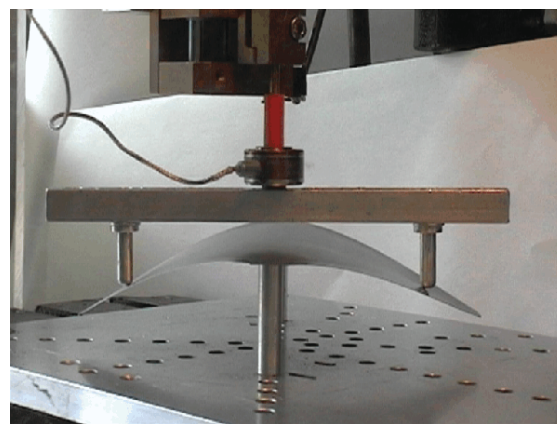

Figure 2: Picture of a CZ wafer right before breaking.

Table I: Listing of different surface treatments prior to stability testing.

group	surface treatment	final thickness [μm]
1	as cut	300
2	2 μm/side CP6	300
3	10 μm/side CP6	290
4	CP6 to 260 μm	260
5	CP6 to 220 μm	220
6	as cut + acidic texturing	300
7	CP6 to 270 μm + acidic texturing	260
8	CP6 to 230 μm + acidic texturing	220
9	CP6 to 270 μm + alkaline texturing	260

material to see the influence of the saw damage on the maximum tensile strength. According to Gerhards [3] the saw damage caused by a wire saw is removed completely after etching off 15-20 μm. Therefore, for group 4, 5, 7-9 it is only important to obtain the correct wafer thickness.

In addition to the saw damage removal by CP6 etching, wafers of group 6-8 were textured by an acidic texturing solution using a mixture of H₂SO₄, HF and HNO₃ in the relation 6:3:1. After etching for 1 minute a porous layer forms at the surface which has to be removed in NaOH (10%) for solar cell processing [4]. Fig. 3a presents a microscopic picture of the resulting surface morphology. The sponge like structure reveals sharp edges and holes in the range of 5 μm in diameter. Group 9 is textured by a Na₂CO₃ alkaline solution which gives good results only on silicon wafers with a (100) crystal orientations like e.g. for CZ. As Tri-Silicon has a (110) crystal orientation, the alkaline texturing technique is normally not used for this material in solar cell processing. Fig. 3b presents the microscopic picture of a CZ wafer after alkaline texturing. The typical random pyramid structure is clearly visible. Due to the sharp edges of the acidic textured surface a lower maximum tensile strength as compared to alkaline textured wafers is expected.

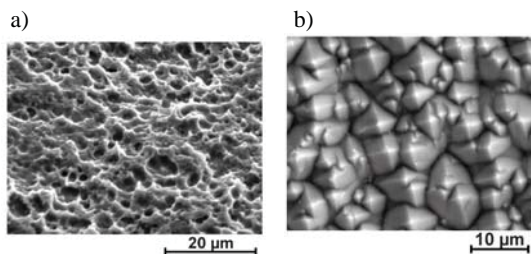

Figure 3: Scanning electron microscope picture of a) acidic b) alkaline textured CZ wafer surfaces.

3 RESULTS

Preliminary examinations revealed that a meaningful statistic can be obtained by averaging over 10 wafers. The mean values for the maximum breakage forces and

the corresponding displacements were calculated for each group by averaging over all wafers of the specific group. The values of wafers with highly diverging values due to small cracks were neglected.

Fig. 4 presents the mean maximum tensile strength in dependence on the mean displacement averaged in general over 10 wafers for Tri-Si and CZ with polish etched surfaces. The error bars give the standard deviations of the mean value of each group indicated by numbers. The solid lines are only guides to the eye and have no experimental background. The first group of both materials is dominated by the saw damage on the surfaces. This leads to the same values of the tensile strength for both materials. With increased saw damage removal (group 2-4) the influence of the saw damage decreases, resulting in higher mean maximum tensile strengths. The highest value is reached after removing ≈20 μm/side. At this point the saw damage is removed completely and the stability of the wafer is only depending on its thickness.

After removing another 20 μm/side the maximum tensile strength decreases drastically. Obviously Tri-Si is more stable than CZ. The mean value of group 4 is 7.4% higher for Tri-Si as compared to CZ. One possible reason for a higher maximum tensile strength could be the interruption of the cleavage planes at the grain boundaries. These planes cannot spread through the whole wafer which results in a higher stability. Another explanation could be the differing crystal orientation as compared to CZ. Based on these results it should be possible to cut thinner Tri-Si wafers without losses in yield. A reduction of material losses as compared to CZ wafers of the same thickness would be the consequence.

Another important property of Tri-Si is its higher stiffness. At a wafer thickness of 220 μm the maximum displacement of Tri-Si is only about 77% of the value of CZ. This could be an advantage in the industrial screen printing process. Deviating coefficients of expansion for silicon ($7.6 \cdot 10^{-6} \text{ K}^{-1}$ [5]) and aluminium ($23.8 \cdot 10^{-6} \text{ K}^{-1}$ [5]) create a bimetal effect, resulting in a bending of the wafer (bow) which might cause problems to the solar cell process and module encapsulation. As the tendency is going towards larger sized solar cells which respond even

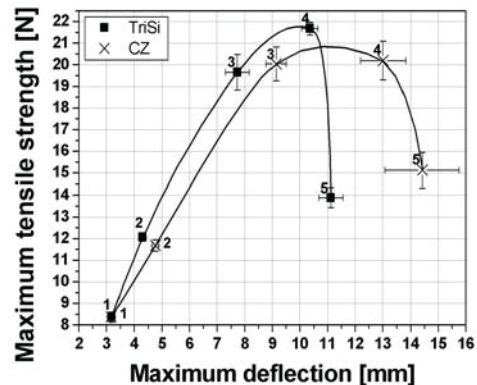

Figure 4: Mean values of the maximum tensile strength in dependency on the maximum displacement of each group. The solid lines are only guides to the eye without experimental background.

more to the bimetal effect, the higher stiffness of Tri-Si should reduce the bow and facilitate the handling.

The second part of this examination was to determine the influence of different surface morphologies on the stability of the silicon wafer. Results are presented in Fig. 5. Again the solid lines are only guides to the eye. The first striking point is the absence of a maximum of the tensile strength (circles and filled squares). Maximum tensile strength for acidic textured wafers is only dependent on the wafer thickness. This leads to the conclusion that the acidic texture removes the saw damage at least partially and introduces a surface damage itself. Comparing group 1 and 6 shows that obviously the introduced breaking points are less harmful than the saw damage. The maximum tensile strength is increased by more than 100%.

Comparing group 6 of both materials, the values are within the error bars. The surface damage introduced by the acidic texture adapt the maximum tensile strengths of Tri-Si and CZ to one another. Only the advantage of a higher stiffness remains valid for Tri-Si.

The dotted line connects CZ groups with the same thickness but different surface morphologies (group 7, 9, and 4). The saw damage is removed for all of the wafers. Afterwards wafers of group 7 and 9 are acidic and alkaline textured, respectively, so their final thickness is 260 μm . The highest tensile strength is found for wafers after saw damage removal with CP6 polish etch solution (group 4). Clearly visible as well is the 20% higher maximum tensile strength of the alkaline textured wafers as compared to the acidic textured ones as predicted above. Qualitatively similar results were published by Stefancich et al. [6].

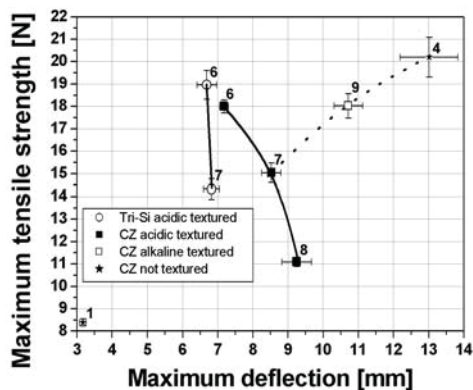

Figure 5: Mean values of the maximum breakage forces over the maximum displacement for different surface morphologies. The solid lines are only guides to the eye.

4. SUMMARY

Tri-silicon has the potential to reduce material losses. This experiment revealed a mean maximum tensile strength for Tri-Si without surface texturisation which is 7.4% higher than the corresponding value of CZ with comparable thickness. As a consequence thinner wafers and a reduction in material losses should be possible. Another positive property of Tri-Si is its increased stiffness as compared to CZ, which holds true even after

texturing the surface. Based on a displacement of only 77% of the value for CZ at the same wafer thickness, Tri-Si should lead to a reduced bow formation in the industrial screen printing process.

The second part of this experiment was to determine the influence of different texturing techniques on the maximum tensile strength. After applying an acidic texture the maximum tensile strengths adapt to one another. In this comparison the acidic texturing solution introduces more surface damage than the alkaline texture resulting in a 26% lower maximum tensile strength as compared to non-textured wafers. The alkaline texturing of the CZ wafers reduces the maximum tensile strength, too, but only by 11%.

5 ACKNOWLEDGEMENTS

This work was supported within the ASIS program by the German Bundesministerium für Umwelt (BMU) under contract number 0329858J.

6 REFERENCES

- [1] G. Martinelli, M.C. Carotta, A.L. Endrös, A study of the mechanical strength on large grain and three-grain thin silicon wafers, Proceedings 14th European Photovoltaic Solar Energy Conference, Vol I (1997) 778.
- [2] H. Behnken, M. Apel, D. Franke, Simulation of mechanical stress during bending tests for crystalline wafers, Proceedings 3rd World Conference on Photovoltaic Energy Conversion (2003) 1308.
- [3] C. Gerhards, PhD thesis, University of Konstanz (2002)
- [4] D. Sontag, G. Hahn, P. Fath, E. Bucher, W. Krühler, Texturing techniques and resulting solar cell parameters on Tri-Silicon material, Proceedings 3rd World Conference on Photovoltaic Energy Conversion (2003) 1304
- [5] C. Gerthsen, H. Vogel, Physik, (Springer, Berlin, 1993)
- [6] M. Stefancich, G. Martinelli, M. Butturi, D. Vincenzi, Effects of chemical texturing on the mechanical resistance of silicon monocrystalline wafers for PV use, Proceedings 16th European Photovoltaic Solar Energy Conference, Vol II (2000) 1584