

Electrogenic Partial Reactions of the SR-Ca-ATPase Investigated by a Fluorescence Method

C. Butscher, M. Roudna, H.-J. Apell

Department of Biology, University of Konstanz, Fach M635, D-78457 Konstanz, Germany

Received: 21 September 1998/Revised: 18 December 1998

Abstract. A fluorescence method was adapted to investigate active ion transport in membrane preparations of the SR-Ca-ATPase. The styryl dye RH421 previously used to investigate the Na,K-ATPase was replaced by an analogue, 2BITC, to obtain optimized fluorescence changes upon substrate-induced partial reactions. Assuming changes of the local electric field to be the source of fluorescence changes that are produced by uptake/release or by movement of ions inside the protein, 2BITC allowed the determination of electrogenic partial reactions in the pump cycle. It was found that Ca^{2+} binding on the cytoplasmic and on the luminal side of the pump is electrogenic while phosphorylation and conformational transition showed only minor electrogenicity. Ca^{2+} equilibrium titration experiments at pH 7.2 in the two major conformations of the protein indicated cooperative binding of two Ca^{2+} ions in state E_1 with an apparent half-saturation concentration, K_M of 600 nM. In state P- E_2 two K_M values, 5 μM and 2.2 mM, were determined and are in fair agreement with published data. From Ca^{2+} titrations in buffers with various pH and from pH titrations in P- E_2 , it could be demonstrated that H^+ binding is electrogenic and that Ca^{2+} and H^+ compete for the same binding site(s). Thapsigargin-induced inhibition of the Ca-ATPase led to a state with a specific fluorescence level comparable to that of state E_1 with unoccupied ion sites, independent of the buffer composition.

Key words: Calcium binding — Ion transport — Binding site — Electrogenicity — Styryl dyes — pH dependence

Introduction

The purpose of the Ca-ATPase in sarcoplasmic reticulum is to pump Ca^{2+} from the cytoplasm into the lumen of the reticulum to promote in this way muscle relaxation. To fulfill this function on the one hand a high transport capacity is required to allow muscle relaxation in approximately 50 msec and, on the other hand, a concentration gradient of 0.1 μM in the cytoplasm and a few millimolar in the lumen has to be maintained in the resting state of muscle cells. Studies on structural and mechanistic properties of the SR-Ca-ATPase are numerous, in accordance with its importance for living organisms, and this protein is one of the best-known ion pumps (Inesi, 1985, Anderson, 1989, Lauger, 1991, Inesi & Sagarra, 1992, Martonosi, 1995, Vilsen, 1995, Zhang et al., 1998). On the basis of the known stoichiometry of 2 Ca^{2+} transported per ATP utilized (de Meis, 1985; Yu & Inesi, 1995) and of the electrogenicity of the pump (Yu et al., 1993; Yu, Hao & Inesi, 1994) the observed Ca^{2+} concentration gradients across the SR membrane are energetically possible only in the absence of a transmembrane voltage (Walz & Caplan, 1988). The absence of an electric membrane potential across the SR membrane is caused by a high ionic permeability for monovalent ions (Hasselbach & Oetliker, 1983).

A consequence of these physiological properties of the SR membranes is that the SR-Ca-ATPase is not directly accessible to electrophysiological investigations. The high leak conductance prohibits the measurements of transmembrane electric events. Therefore, the electrogenicity and the stoichiometry of the Ca^{2+} pump was controversial for a long time (Lauger, 1991). Recently, clear cut evidence was presented by Yu and collaborators who circumvented the problem of the highly permeable native SR vesicles and demonstrated by experiments with SR Ca-ATPase reconstituted in proteoliposomes

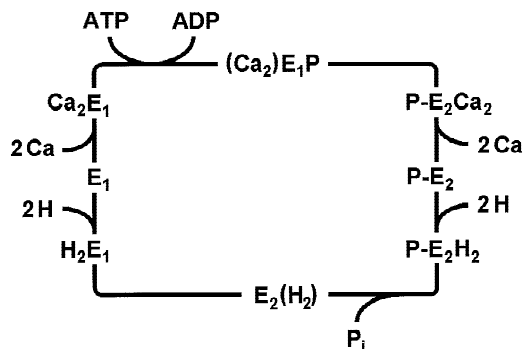

Fig. 1. Simplified pump cycle of the SR-Ca-ATPase on the basis of a H^+/Ca^{2+} exchange model (Yu et al., 1994). E_1 and E_2 represent the two basic conformations of the protein in which may be defined by the accessibility of the binding sites for Ca^{2+} ions on the cytoplasmic or luminal side of the SR membrane, respectively. In states $(Ca_2)E_1P$ and $E_2(H_2)$ the ions are occluded, i.e., they cannot exchange with either aqueous phase. The scheme is based on a transport stoichiometry of $2 Ca^{2+}/2H^+/1ATP$.

that the stoichiometry is $2 Ca^{2+}/2 H^+/1 ATP$ and that the pump is electrogenic (Yu et al. 1993, 1994).

The application of fluorescent dyes, such as Oxonol VI, to measure electrogenic ion transport in reconstituted vesicles, however, provides only very restricted insight into the kinetics and electrogenic contributions of partial reactions to the function of ion pumps (Apell & Bersch, 1987). Therefore a different strategy has been developed to obtain access to such information. In the case of the Na,K-ATPase, styryl dyes, especially RH421, are applied successfully to investigate various partial reactions of the pump cycle (Klodos & Forbush, 1988, Stürmer et al., 1991, Heyse et al., 1994, Apell et al., 1996). The detection mechanism of styryl dyes is based mainly on their electrochromic behavior under specific experimental conditions, i.e., low dye concentrations in the order of 200 nM, and excitation at the far red edge of the absorption spectrum (Bühler et al., 1991). This means that an observed fluorescence decrease or increase occurs when a positive charge is imported into or is removed from the protein, respectively. Since the styryl dyes report essentially the change of local electric fields within the protein/membrane dielectric, and to a much lesser extent transmembrane electric potentials, this method can be applied to open membrane fragments (as in the case of the Na,K-ATPase) or to leaky vesicular membranes (as in the case of SR membranes).

Therefore it is opportune to apply this method to the investigation of the SR-Ca-ATPase. As the basis of our investigations we refer to a pump cycle which we derived from Yu et al. (1994) as shown in Fig. 1. This reaction sequence accounts essentially for all observations with respect to the ion transport mechanism and shows the substrate-dependent partial reactions which are easily accessible to experimental investigation. In

the light of the high structural similarities between Na,K-ATPase and SR-Ca-ATPase (Vilsen, Ramlov & Anderson, 1997; Vilsen 1998) it may be assumed that, correspondingly, ion-binding and release steps may be the main contributors to the electrogenicity of the SR Ca-ATPase.

The aims of this presentation are as follows: (i) the establishment of an experimental technique using an appropriate styryl dye to investigate electrogenic partial reactions of the SR Ca-ATPase, electrogenic partial reactions being defined as transitions between states of the pump cycle in which electric charge is moved within the protein dielectric perpendicular to the plane of the membrane, (ii) the identification of the electrogenic reaction steps in the pump cycle, and (iii) the presentation of additional evidence for binding of H^+ ions to the Ca^{2+} binding sites and for H^+ counter transport.

Materials and Methods

Phosphoenolpyruvate, pyruvate kinase, lactate dehydrogenase, NADH, ATP (disodium salt, special quality) were from Boehringer (Mannheim). Thapsigargin and thapsigargin were purchased from Sigma (München). RH 421 (N-(4-Sulfobutyl)-4-(4-(4-(dipethylamino)phenyl)butadienyl)pyridinium, inner salt), Fura-2 and BAPTA (1,2-bis(2-aminophenoxy)-ethane-N,N,N',N' tetrasodium salt) were obtained from MoBiTec (Göttingen), EGTA (Ethylenglycol O,O'-bis(2-aminoethyl)-N,N,N',N' tetraacetic acid) and Bis-Tris (Bis(2-hydroxyethyl)amino-tris (hydroxymethyl) methane) from Fluka (Buchs, Switzerland). NaCl (suprapure quality) and all other reagents (at least analytical grade) were from Merck (Darmstadt). 2BITC (1-[4-isothiocyanato-n-butyl]-4-[(p-N,N-diethylamino)styryl]pyridinium bromide) was synthesized in the Institute of Organic Chemistry and Macromolecular Chemistry at the University of Düsseldorf, Germany, by M. Birmes and S. Beutner according to Birmes (1995).

SR-Ca-ATPase was prepared by a slight modification of the method of Heilmann et al. (1977) from the psoas muscle of rabbits. The whole procedure was performed at temperatures below 4°C. The determination of the protein content of the membrane preparation was performed according to Markwell et al. (1978). The most active fractions of the final density gradient separation had a protein content of 2–3 mg/ml. The enzymatic activity was determined by the pyruvate kinase/lactate dehydrogenase linked-assay (Schwartz et al., 1971) in a buffer containing 2 μM of free Ca^{2+} . Background enzymatic activity of the isolated preparation was obtained by either quantitative removal of the free Ca^{2+} by 5 mM EGTA or addition of 1 μM thapsigargin. The Ca-ATPase specific activity was about 2.5 units/mg at 25°C (which corresponds to 2.5 μmol ATP hydrolyzed per mg protein per min) and could be increased to 3 units/mg in the presence of A23187 and FCCP to short-circuit the membranes completely.

To determine the free Ca^{2+} concentrations in buffers used for experiments two methods were applied. In the concentration range above 1 μM an electrode with the Ca-selective Membrane ETH129 was used. The slope of the linear calibration curve was 25 mV/pCa in calibration buffers containing 10 mM EGTA, 1 mM $MgCl_2$, 25 mM Tricine, 50 mM KCl, pH 7.2, and varying concentrations of $CaCl_2$. This slope is close to previously published data (Schefer et al., 1986). In the range between 17 nM and 3 μM the free Ca^{2+} concentration was determined fluorimetrically using the ratiometric indicator dye Fura-2 (Gryniewicz, Poenie & Tsien, 1985). The calibration was performed with commercially available buffers (MoBiTec, Göttingen).

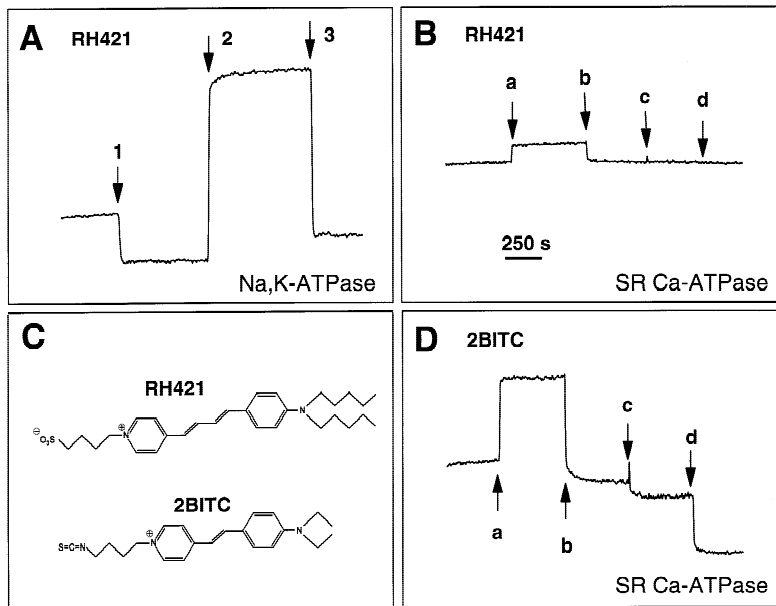

Fig. 2. Investigation of electrogenic partial reactions of the Na,K-ATPase and the SR-Ca-ATPase by electrochromic styryl dyes. (A) The dye RH421 has been successfully applied to study electrogenic reaction steps of the Na,K-ATPase which can be obtained by substrate additions. (1) + 50 mM Na^+ : $\text{E}_1 \rightarrow \text{Na}_3\text{E}_1$, (2) + 1 mM ATP: $\text{Na}_3\text{E}_1 \rightarrow \text{P-E}_2$, (3) + 40 mM K^+ : $\text{P-E}_2 \rightarrow \text{E}_2(\text{K}_2)$. (B) RH421 is not sensitive to substrate-induced reaction sequences in the case of the Ca-ATPase containing SR membranes. To a buffer which initially contains 25 mM tricine, 50 mM KCl, 1 mM MgCl_2 (pH 7.2), 200 nM RH421, and 9 $\mu\text{g}/\text{ml}$ protein, following additions were made to give the final concentrations of (a) 0.1 mM EGTA, (b) 190 μM Ca^{2+} , (c) 1 mM ATP, (d) 15 mM Ca^{2+} . The maximum fluorescence changes were less than 15%. (C) Chemical structures of the two styryl dyes applied in studies of the Na,K-ATPase, RH421, and of the Ca-ATPase, 2BITC. (D) In contrast to RH421, 2BITC produced significant fluorescence changes when the experiment shown in panel B was repeated with 200 nM 2BITC instead of RH421. A repetition of the experiment in panel A with 200 nM 2BITC gave only small fluorescence changes (not shown).

Fluorescence measurements were performed in a fluorescence spectrometer LS 50B (Perkin Elmer, Überlingen) in quartz cuvettes of 1 or 2 ml effective volume to obtain iontransport specific data. The cuvette holder was thermostated at 20°C (if not otherwise mentioned) and equipped with a magnetic stirrer. The styryl dye RH 421, which was applied successfully with the Na,K-ATPase (Heyse et al., 1994, Apell et al., 1996) was used in control experiments. In these experiments the dye concentration was 200 nM, the excitation wavelength was 590 nm (slit width 15 nm), and the emission wavelength 650 nm (slit with 20 nm).

Results

OPTICAL DETECTION OF ELECTROGENIC REACTION STEPS IN THE SR-Ca-ATPASE

Since the styryl dye RH421 was applied successfully on the Na,K-ATPase to analyze electrogenic partial reactions, we tried to use the same approach with the SR-Ca-ATPase. In Fig. 2A and B so-called “standard experiments” are shown which are performed with the Na,K-ATPase and the SR-Ca-ATPase in the presence of 200 nM RH421. The standard experiment with the Na,K-ATPase started in a buffer which initially contained 30 mM histidine, 1 mM EDTA, 5 mM MgCl_2 , pH 7.2, 200 nM RH421, and 8 $\mu\text{g}/\text{ml}$ protein. The experiment was performed by consecutive addition of substrates to reach well-defined states in the pump cycle of the ion pump. The states obtained in Fig. 2A were E_1 (initial state), Na_3E_1 (+50 mM NaCl), P-E_2 (+ 1 mM ATP) and $\text{E}_2(\text{K}_2)$

(+ 20 mM KCl) (Stürmer et al., 1991; Stürmer & Apell, 1992). Significant fluorescence changes were observed and could be used to identify and analyze electrogenic reaction steps (for recent review see Apell, 1997). The fluorescence change induced by addition of ATP was in the order of 100%. A corresponding standard experiment with the SR-Ca-ATPase was performed in a buffer initially containing 25 mM tricine, 50 mM KCl, 1 mM MgCl_2 , and approximately 200 nM Ca^{2+} (according to Fura-2 measurements), pH 7.2, and 200 nM fluorescent dye. About 150 sec after addition of the dye the protein (9 $\mu\text{g}/\text{ml}$) was added. A stable fluorescence intensity was obtained typically after a few minutes. The initial state of the ion pump under this buffer condition was not well defined, we named it Ca_xE_1 with approximately $x \leq 1$. In the experiment presented in Fig. 2B and D the states induced by substrate addition were E_1 (+ 0.1 mM EGTA, Ca_2E_1 (190 μM CaCl_2), P-E_2 (+ 1 mM ATP), and $\text{P-E}_2\text{Ca}_2$ (+ 15 mM CaCl_2). As can be seen from Fig. 2B only the addition of EGTA and Ca^{2+} in the state E_1 produced a fluorescence increase/decrease in the order of 15%. Enzyme phosphorylation and Ca^{2+} binding in the state P-E_2 could not be detected by significant fluorescence changes ($\Delta F \leq 2\%$). On the basis of these findings RH421 was rejected as a useful probe to investigate the electrogenic steps of the Ca-pump. After screening of a large number of analogues of a family of styryl dyes which were synthesized in the Institute of Organic Chemistry and Macromolecular Chemistry at the University of Düsseldorf we selected the styryl dye 2BITC

(Birmes, 1995) as a suitable probe for the Ca-ATPase in membranes of the sarcoplasmic reticulum (*manuscript in preparation*). Its structure is shown in Fig. 2C. The corresponding standard experiment in the presence of 200 nM 2BITC is shown in Fig. 2D. It was performed exactly as described above for experiments with RH421. Under this buffer condition, values of the substrate-induced relative fluorescence changes were between 8% and 40%, sufficient for detailed analysis.

The concentration of 2BITC was varied between 100 and 1600 nM to check the effect of dye concentration on the substrate-specific fluorescence responses. Changing the ratio of dye to Ca-ATPase by a factor of 16 did not significantly alter the relative fluorescence changes after substrate additions. Up to 1,000 nM, the fluorescence intensity increased linearly with concentration, above 1,000 nM a tendency to saturation became visible (*data not shown*). Since no covalent binding of 2BITC to the pump protein could be detected we assume that the dye is distributed in the lipid phase as described for the analogue RH421 (Bühler et al., 1991). A series of control experiments was performed to ensure that the substrate-induced fluorescence changes are protein specific responses. Standard experiments for the Ca-ATPase as defined above were performed with protein-free lipid vesicles to check for fluorescence changes induced by interaction of the substrates EGTA, Ca^{2+} , and ATP with the dye 2BITC dissolved in the lipid phase. In addition, experiments were performed with SR membranes incubated for 20 min at 56°C to destroy the enzymatic activity (the residual enzymatic activity was less than 5% of that before incubation). In both types of control experiments no significant fluorescence changes were observed when 0.1 mM EGTA, 0.19 mM Ca^{2+} , and 1 mM ATP were added ($|\Delta F/F_0| \leq 1\%$, *data not shown*). Addition of 15 mM Ca^{2+} resulted in a fluorescence decrease of 19% which has to be attributed to a nonspecific effect. This nonspecific effect was investigated separately by titration of the free Ca^{2+} concentration between 10 μM and 100 mM. In lipid vesicles as well as in thermally inactivated SR membranes the fluorescence intensity was not significantly affected in the concentration range between 10 μM and 1 mM Ca^{2+} . For higher concentrations the fluorescence declined about 30% with a half saturating concentration of 13 mM in vesicles (*not shown*) and 19 mM in SR membranes (*cf.* Fig. 5B). Similar Ca^{2+} -concentration dependent effects were recorded also with tharpsigargin-inhibited SR membranes (*not shown*).

An obvious result of the experiments with 2BITC (as well as with RH421 to a lesser extent) was that significant fluorescence changes were observed in those partial reactions in which Ca^{2+} binding or release was involved. In agreement with the mechanism of these styryl dyes, which is predominantly an electrochromic ef-

fect in the case of a red-edge excitation, a fluorescence increase is caused by a decrease of an intramembrane electric potential and a fluorescence decrease by an increase of an intramembrane electric potential (Loew et al., 1979; Bühler et al., 1991). This indicates that Ca^{2+} binding to and release from the Ca-ATPase is an electrogenic event by which the ions move through part of the protein dielectric to shuttle between binding sites and the aqueous phase.

Inhibition of the SR-Ca-ATPase by Tharpsigargin

Tharpsigargin is known to be a potent and specific inhibitor of the SR-Ca-ATPase (Inesi & Sagara, 1992) which binds stoichiometrically to the enzyme (Sagara & Inesi, 1991) and stabilizes the transmembrane region of the ATPase (De Meis & Inesi, 1992). To test the effect of tharpsigargin on the 2BITC-labeled membrane preparations, standard experiments were performed in which tharpsigargin was added to a final concentration of 0.5 μM (from a 1 mM solution in DMSO) under various substrate conditions. In Fig. 3A an experiment is shown in which tharpsigargin was present before the series of additions of the standard experiment as shown in Fig. 2D. In contrast to all other additions (EGTA, Ca^{2+} , ATP) a steady-state level of fluorescence was obtained only very slowly (<500 sec). The time course to reach steady state depended on the tharpsigargin concentration (*not shown*). Subsequent additions of 0.1 mM EGTA, 190 μM Ca^{2+} and 1 mM ATP induced only minor fluorescence changes. Only addition of 15 mM Ca^{2+} caused a significant drop of the fluorescence level. A synopsis of the experiments in which tharpsigargin was added in different states of the pump cycle is shown in Fig. 3B. Addition of the tharpsigargin always led to a fluorescence increase from a level of the standard experiment without tharpsigargin to the level of the inactivated enzyme, independent of the substrate composition in the buffer. A comparison of the fluorescence intensities after the second addition of Ca^{2+} (15 mM) reveals on the one hand the nonspecific effect of the high Ca^{2+} concentration on 2BITC, since the fluorescence decrease in the presence of tharpsigargin cannot be caused by a protein-specific function, and, on the other hand, that the inhibitor addition in the presence of high Ca^{2+} initiated a transition of the ion pump into its inhibited state and this protein-specific reaction is accompanied by a significant fluorescence increase. This is an indication of an electrogenic contribution of the transition into the inhibited state of the SR-Ca-ATPase.

The effect of the tharpsigargin concentration on fluorescence intensity is shown in Fig. 3C. Increasing concentrations of tharpsigargin were added to 2BITC-labeled preparations in standard buffer and the corresponding increase of fluorescence intensity was recorded

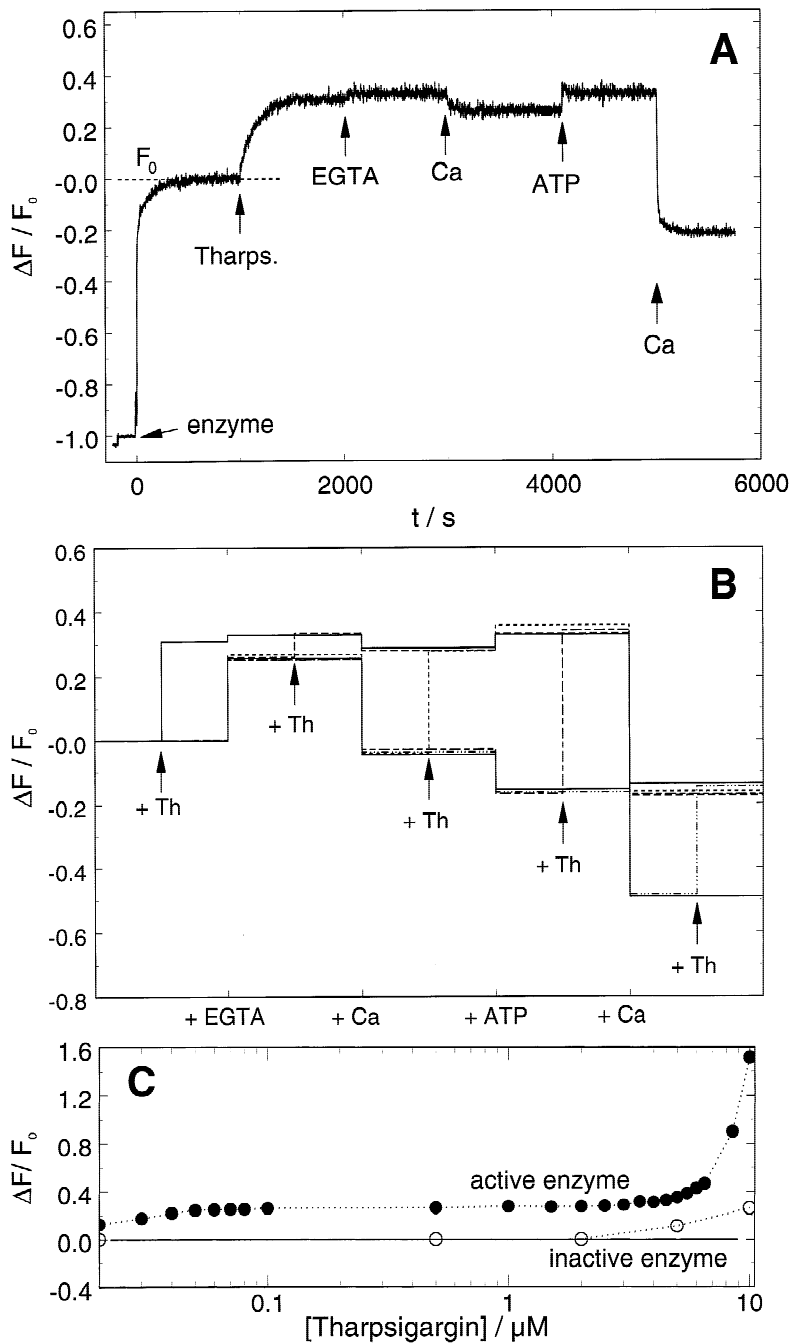

Fig. 3. Effect of thapsigargin on 2BITC labeled membrane preparations. The buffer conditions were the same as shown in Fig. 2B. (A) Standard experiment in the presence of $0.5 \mu\text{M}$ thapsigargin. The fluorescence intensity was normalized to the level prior to addition of the inhibitor, F_0 . The inhibited enzyme produced only small intensity changes when 0.1 mM EGTA, $190 \mu\text{M}$ Ca^{2+} , and 1 mM ATP were added. Addition of 15 mM Ca^{2+} led to a partly nonspecific drop of 40%. (B) Thapsigargin was added to the membrane preparation at various stages of the standard experiment (+ Th). In each substrate-specific state the same thapsigargin-induced fluorescence level was observed independent of the state at which the inhibitor was added. (C) Concentration dependence of the thapsigargin-induced fluorescence increases. Untreated and thermally inactivated preparations are compared. The strong fluorescence increase above $5 \mu\text{M}$ thapsigargin is assigned to a nonspecific interaction between inhibitor and dye since it was observed in both membrane preparations in a similar way.

up to a concentration of $10 \mu\text{M}$. In a concentration range of thapsigargin up to $5 \mu\text{M}$ the fluorescence increase was $\sim 27\%$ with respect to F_0 . The half-saturating concentration for this effect was $\leq 10 \text{ nM}$. When, in a control experiment, the inhibitor was added to thermally inactivated ATPases in SR membranes (*see above*) no 2BITC-fluorescence change was observed. Above $5 \mu\text{M}$ thapsigargin, the fluorescence increased strongly with concentration and this effect was interpreted as a nonspecific artifact of the inhibitor as a lipid-soluble com-

pound on the fluorescence of the dye since it could be observed also with thermally inactivated preparations.

Calcium Titration in State E_1 of the SR-Ca-ATPase

An additional control for the detection of Ca^{2+} binding by the fluorescence decrease was the reproduction of the known binding affinity of the Ca-ATPase. To buffer containing 25 mM tricine, 50 mM KCl, 1 mM MgCl_2 , pH

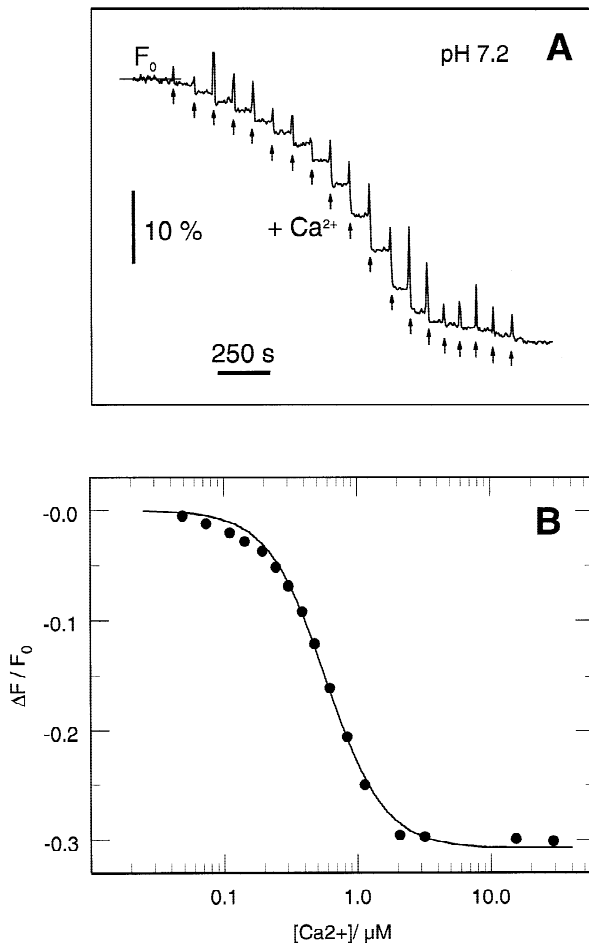

Fig. 4. Fluorescence changes induced by Ca^{2+} equilibrium titration experiments of the Ca-ATPase in its E_1 conformation. (A) Representation of an original experiment. Buffer composition as given in Fig. 2B. The fluorescence intensity in buffer after addition of 0.1 mM EGTA was defined as F_0 , relative to which the fluorescence changes were normalized: $\Delta F/F_0 = (F - F_0)/F_0$. The precise Ca^{2+} concentration after each addition of CaCl_2 (arrows) was determined by a FURA-2 experiment performed in parallel. (B) The relative fluorescence changes, $\Delta F/F_0$, are plotted against Ca^{2+} concentration and the data could be fitted by a Hill function (Eq. 1) with a half saturating Ca^{2+} concentration, K_M , of 595 nM and a Hill coefficient, n , of 2, which indicates a strictly cooperative binding of 2 Ca^{2+} ions. This result is in good agreement with published data on the cytoplasmic binding affinity and supports the proposal that 2BITC detects the Ca^{2+} binding to the ion pump.

7.2, and 200 nM 2BITC, SR membranes (18 $\mu\text{g}/\text{ml}$) were added and equilibrated until a stable fluorescence level was obtained. Then BAPTA was added to a final concentration of 0.1 mM to remove nominally all Ca^{2+} ions bound to the ATPase which is reflected by an increase of the fluorescence intensity. Then aliquots of CaCl_2 solutions were added and the fluorescence decrease recorded (Fig. 4A). In parallel, exactly the same experimental protocol was performed in a cuvette which contained in

addition 333 nM FURA-2 as an optical indicator to determine the precise free Ca^{2+} concentrations in the range below 1 μM . The normalized fluorescence changes of the 2BITC signal, $\Delta F/F_0 \equiv (F(E_1 + \text{Ca}^{2+}) - F(E_1))/F(E_1)$, were plotted against the Ca^{2+} concentration (Fig. 4B) and fitted by a Hill function

$$\frac{\Delta F}{F_0} = \frac{\Delta F}{F_0} \Big|_{\text{max}} \times \frac{1}{1 + (K_M/[\text{Ca}^{2+}])^n} \quad (1)$$

At pH 7.2 (shown in Fig. 4B) the maximum fluorescence change, $\Delta F/F_{0\text{max}}$, was about -31% , the half-saturating Ca^{2+} concentration, K_M , was 600 ± 20 nM, and the Hill coefficient, n , was $2 (\pm 0.1)$. This finding supports the assumption that changes of 2BITC fluorescence reflect Ca^{2+} binding to the Ca-ATPase and that this process is electrogenic.

Calcium Titration in State P- E_2 of the SR-Ca-ATPase

The effect of Ca^{2+} binding to the sites presented at the luminal interface in the P- E_2 conformation of the Ca-ATPase was investigated by the following experiments. To buffer containing 25 mM tricine, 50 mM KCl, 1 mM MgCl_2 , pH 7.2 and 200 nM 2BITC, SR membranes (18 $\mu\text{g}/\text{ml}$) were added followed by ATP to a final concentration of 1 mM and the suspension was equilibrated until a stable fluorescence intensity was obtained. According to measurements with a Ca^{2+} -sensitive electrode under this condition (in the absence of a chelator) the free Ca^{2+} concentration was 5 ± 1 μM . Therefore it could be assumed that the proteins were preferentially in state P- E_2 . By addition of various aliquots from CaCl_2 stock solutions (25 mM to 1.6 M) the ion concentration was increased up to 82 mM and the accompanying 2BITC fluorescence was recorded (Fig. 5A). Above 20 mM a beginning saturation of the fluorescence decrease began to be observed (Fig. 5B). Unfortunately, control experiments with pure lipid vesicles and with SR membranes inhibited thermally or by 0.5 μM thapsigargin before addition of ATP revealed that Ca^{2+} concentrations above 1 mM affected the 2BITC fluorescence intensity as demonstrated in Fig. 5B (open circles). In the case of RH421 high Ca^{2+} concentrations did not affect the fluorescence intensity (Fig. 2B). A possible origin of this effect may be adsorption of the divalent ions on the membrane surface which generates an electrostatic interaction with the dye molecules. When the difference between the fluorescence changes of active and inhibited protein was determined, a significant fluorescence decrease remained (open squares in Fig. 5B). The remaining fluorescence decrease ($\Delta F/F_{0\text{max}} = -25\%$) indicated an electrogenic Ca^{2+} binding in state P- E_2 . The difference signal can be approximated by the sum of two binding isotherms with

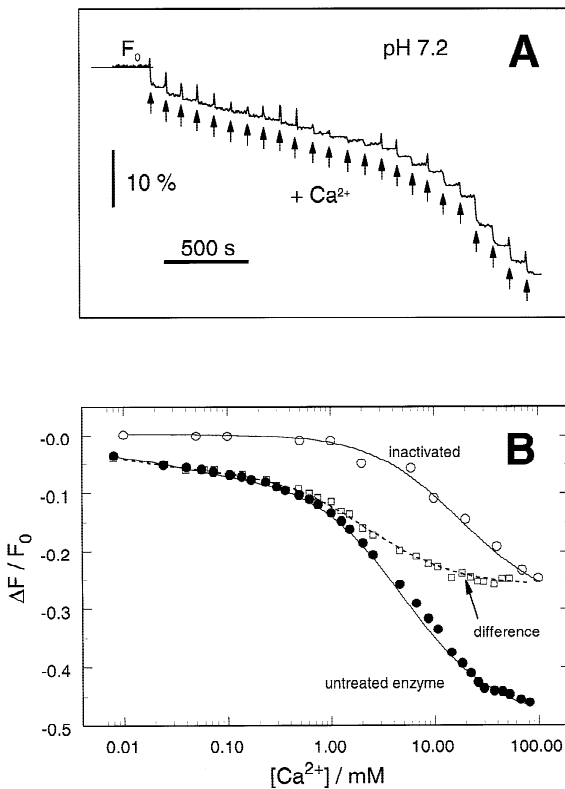

Fig. 5. Fluorescence changes induced by Ca^{2+} equilibrium titration experiments of the Ca-ATPase in its P- E_2 conformation. (A) Representation of an original experiment. Buffer composition as given in Fig. 2B. The fluorescence intensity in buffer after addition of 1 mM ATP was defined as F_0 . (B) The relative fluorescence changes, $\Delta F/F_0$, are plotted against Ca^{2+} concentration. The filled circles represent two overlaid titration experiments with uninhibited enzyme. The data could be fitted by the sum of two binding isotherms (line). To determine the nonspecific effect of high Ca^{2+} concentrations (>1 mM) on 2BITC in SR-membranes experiments similar to the one shown in panel A were repeated with thermally inactivated SR membranes. The nonspecific effect of Ca^{2+} on 2BITC (open circles) could be fitted phenomenologically by a binding isotherm with a K_M of 19 mM. The difference between the experimental data (filled circles) and the binding isotherm was calculated and plotted (open squares). The resulting fluorescence decrease could be fitted by a sum of two binding isotherms (dashed line) with half saturation Ca^{2+} concentrations of 5 μM and 2.2 mM.

equilibrium dissociation constants of $5 \pm 1.2 \mu\text{M}$ and 2 ± 0.2 mM at pH 7.2 as shown in Fig. 5B (dashed line).

pH Dependence of Ca^{2+} -binding Reactions

Further experiments were performed to investigate the effect of pH on the fluorescence intensity of 2BITC and of the SR-Ca-ATPase which has been shown to transport H^+ ions as counter ion to Ca^{2+} (Yu et al., 1994). First we performed the standard experiment as shown in Fig. 2D, but varied pH between 6.2 and 8.0. The buffer compo-

sition corresponded to that of Fig. 2D with the exception of the chelator: 100 μM EGTA was replaced by 100 μM BAPTA, which is much less pH sensitive with respect to its affinity for Ca^{2+} . The results are represented in Fig. 6, in which the fluorescence changes were normalized to the fluorescence intensity prior the first substrate addition (0.1 mM BAPTA). It can be seen that under buffer conditions in which the ion-binding sites were saturated with Ca^{2+} in E_1 as well as in P- E_2 , the fluorescence levels were not significantly different in buffers of pH between 6.2 and 8. This is a strong indication that 2BITC is not a pH indicator. Direct pH titration experiments with lipid vesicles and 2BITC confirmed that there were no significant changes of the fluorescence level in the range of pH 5.5 to 8 (*data not shown*).

When the ion binding sites could be assumed to be virtually free of Ca^{2+} after addition of 0.1 mM BAPTA ($[\text{Ca}^{2+}] < 20$ nM) in state E_1 and in state P- E_2 (in the presence of $\sim 30 \mu\text{M}$ Ca^{2+}) it could be observed that the fluorescence levels exhibited a distinct pH dependence. This effect can be assigned to an ion-pump specific process which has electrogenic components. On the basis of the findings of Yu et al. (1994) in reconstituted vesicles, it was a reasonable assumption to correlate the fluorescence changes with proton binding to the ion sites.

Therefore pH dependence of the two sensitive states of the Ca-ATPase, E_1 and P- E_2 , was investigated in a second step. In Fig. 7 the results of two series of experiments are shown. The fluorescence responses in conformation E_1 were determined in standard buffers, in which the pH was adjusted by HCl or KOH to the indicated value. 200 nM 2BITC and SR membranes (9 $\mu\text{g}/\text{ml}$ protein) were added and equilibrated at 20°C until a stable fluorescence intensity was obtained. Then BAPTA was added to a final concentration of 0.1 mM and the fluorescence increase was monitored. Further addition of BAPTA did not change the fluorescence intensity.

The fluorescence increase was normalized to the level before addition of the chelator and plotted against buffer pH. In Fig. 7A the results of experiments with one preparation are shown (filled circles). Results of repetitions with different enzyme preparations did not vary significantly. The normalized fluorescence levels obtained in the pH range between 7 and 5.6 could be fitted by a Hill function with a pK of 5.9 and a Hill coefficient, n , of 1.6 (solid line in Fig. 7A). As a complementary experiment pH titrations were performed. After BAPTA addition at pH 8 as described above, aliquots of HCl were added and the pH of the buffer reduced stepwise to 5.6. The fluorescence levels were detected, normalized and plotted against their corresponding pH values (Fig. 7A, open circles). The results of both experiments agreed well. The reduced $\Delta F/F_{0\text{max}}$ at pH > 7 is not understood so far.

To investigate the effect of pH on fluorescence in

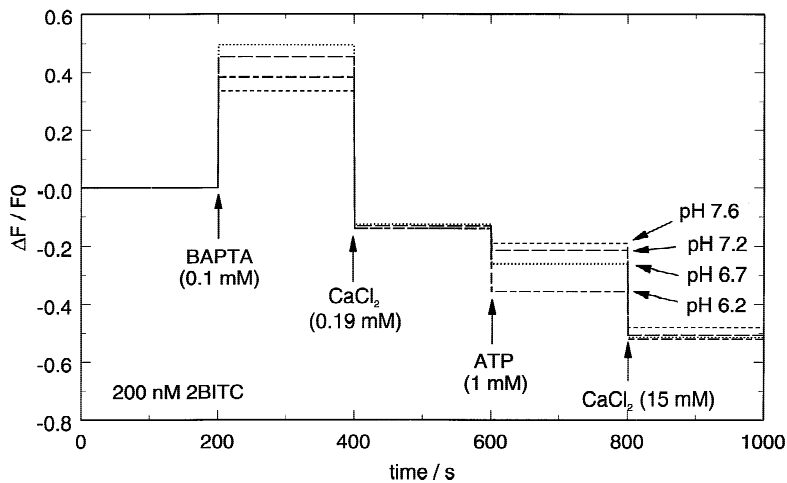

Fig. 6. Standard experiments performed in buffers of different pH. Relative fluorescence changes were normalized to the intensity prior the addition of 0.1 mM BAPTA. It is obvious that in states in which binding sites were not occupied by (saturating) Ca^{2+} but were accessible to H^+ ions (states E_1 and P-E_2) a significant effect of pH on the fluorescence was found. In state P-E_2 a monotonic fluorescence decrease with increase of H^+ concentration was observed. In state E_1 a maximum effect on fluorescence intensity was found at pH 6.7.

conformation P-E_2 , experiments were performed in standard buffers in which the initial pH was adjusted to 8 with KOH. After addition of 200 nM 2BITC, SR membranes (9 $\mu\text{g}/\text{ml}$ protein) and 1 mM ATP, the cuvette was equilibrated at 20°C until a stable fluorescence intensity was obtained. Since no chelator was present the unbuffered Ca^{2+} concentration was about 1–5 μM . This fluorescence level was defined to be F_0 . Then an aliquot of HCl was added, the fluorescence decrease to the new stationary level was monitored and then the pH was measured by a pH electrode. pH steps were performed in the range between 8 and 5.35. The fluorescence changes were normalized with respect to F_0 and plotted against the pH after addition of HCl (Fig. 7B). The pH dependence of $\Delta F/F_0|_{\text{max}}$ could be fitted by a simple binding isotherm with a pK below 5.5. The observation that the fluorescence did not change significantly above pH 7 indicated that the fluorescence decrease in this pH range as shown in Fig. 7A is not a nonspecific effect of the dye or the SR membranes.

Besides a direct effect of the H^+ concentration on 2BITC fluorescence, it could be shown that pH could also affect Ca^{2+} binding in state E_1 on the cytoplasmic side of the ion pump. Ca^{2+} titration experiments as described above (Fig. 4) were repeated in buffers with a pH adjusted to a value between 6.15 and 7.6, and the half-saturating Ca^{2+} concentration, K_M , was determined for each titration by a fit of the concentration dependence with the Hill equation (Eq. 1). The results are shown in Fig. 8. Significantly higher Ca^{2+} concentrations were necessary at low pH to cause the same effect as in high pH buffers. The dashed line drawn in Fig. 8 was simulated under the assumption that 2 H^+ ions can bind to the twofold negatively charged ion sites (Yu et al., 1994), and thus decrease the affinity of Ca^{2+} binding. An apparent pK was determined to be 7.2 from the curve fitting the experimental data. The proton-independent equilibrium dissociation constant for Ca^{2+} was estimated to be

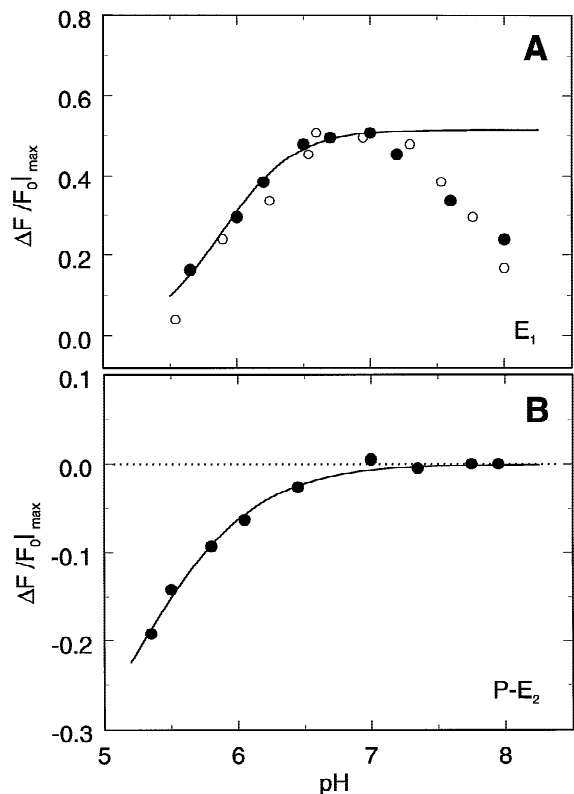

Fig. 7 pH titration of the SR-Ca-ATPase in conformation E_1 and P-E_2 as detected by 2BITC fluorescence changes. (A) In E_1 the normalized fluorescence changes $\Delta F/F_0|_{\text{max}}$ were obtained by addition of BAPTA to remove all Ca^{2+} from the ion pumps. The pH was maintained in the buffer by appropriate additions of HCl or KOH. The line represents the fit of a Hill function (Eq. 1) to the data between pH 5.6 and 7 with a K_M of 1.26 μM (or pK 5.9) and $n = 1.6$. (B) In P-E_2 the enzyme was 'locked' initially in this state by the presence of $\sim 5 \mu\text{M}$ Ca^{2+} and 1 mM ATP. Addition of various aliquots of HCl reduced the buffer pH and the corresponding fluorescence change was monitored. The line represents a binding isotherm with a K_M below 3.2 μM (pK < 5.5).

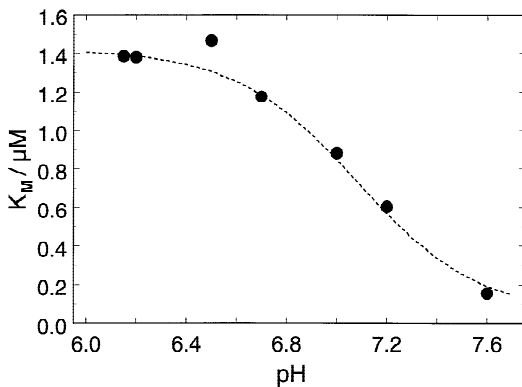

Fig. 8. pH dependence of cytoplasmic Ca^{2+} binding in terms of the half-saturating Ca^{2+} concentration, K_M , determined from Ca^{2+} titration experiments at various pH as shown in Fig. 4 at pH 7.2. The dashed line corresponds to a competitive binding of two protons with an apparent pK of 7.1 to the negatively charged ion binding sites (see text).

in the order of 50 nm. It was increased to about 1450 nm at saturating H^+ concentrations.

Discussion

The experiments presented with SR membrane preparations and the styryl dye 2BITC demonstrate that it is possible to investigate electrogenic events in the SR-Ca-ATPase despite the high native leakage of these membranes which prevents direct electrophysiological measurements. Most known ion pumps are 'electrogenic', i.e., they translocate net charge across the membrane (Lauser, 1991). This definition has been extended to partial reactions of the pump cycle. Electrogenicity is defined there as a property of reaction steps in which charge is moved through (part of) the protein/membrane with a low dielectric constant. The electrogenic contributions of such reaction steps may be described in terms of dielectric coefficients, and the sum of the dielectric coefficients of all reaction steps in the pump cycle equals the net charges translocated across the membrane (Lauser & Apell, 1986, Lauser, 1991). Styryl dyes, especially RH421, were used with great success to investigate Na,K-ATPase-containing membrane preparations (Klodos & Forbush, 1988, Sturmer et al., 1991, Pratap et al., 1993; Heyse et al., 1994, Fedosova, Cornelius & Klodos, 1995; Kane et al., 1995; Apell et al., 1996; Clarke et al., 1998). Significant fluorescence changes have been observed in all partial reactions which contain electrogenic reaction steps.

Na,K-ATPase-containing membrane fragments are open structures in which both faces of the membrane are accessible to the same buffer and therefore are electrically short circuited. The observed changes of the fluorescent dye may not be generated by transmembrane po-

tentials but by changes of local electrical fields mainly on the basis of the mechanism of electrochromy (Buhler et al., 1991; Grinvald et al., 1982). Therefore this principle should also be applicable for SR membranes. Experiments using the styryl dye RH421 turned out to detect some fluorescence changes induced by Ca^{2+} binding and release steps, however, the changes were small and therefore rather sensitive to nonspecific drift effects of the fluorescence intensity (Fig. 2B). From previous investigations it was already known that various styryl dyes differ up to a factor of ten in their fluorescence response when applied to the same partial reactions of the Na,K-ATPase. Therefore, a variety of analogous styryl dyes was tested for their substrate-dependent response with the Na,K-ATPase and SR-Ca-ATPase (*manuscript in preparation*), and the dye 2BITC (Fig. 2C) was found to be an excellent candidate for studies of electrogenic partial reactions of the Ca-ATPase. According to the physical mechanism of RH421, which is same for 2BITC due to the analogous chemical structure (Fig. 2C), a fluorescence decrease is caused by an increased positive charge within the membrane dielectric, a fluorescence increase by an increased negative (or decreased positive) charge respectively.

The investigation of the mechanism of 2BITC is still under progress. So far it is justified to assume that it functions in the same way as RH421 does since its voltage-dependent spectral properties are in good agreement with those of RH421 (*manuscript in preparation*). However, a flip-flop of 2BITC molecules between both lipid layers of the microsomal membrane may not yet be excluded. Such a permeation of dye molecules to the inner hemileaflet of the microsomal membrane could contribute to the differences of the fluorescence responses between 2BITC and the completely impermeable RH421.

A standard experiment was defined by a sequence of substrate additions with respect to the pump cycle of the Ca-ATPase (Fig. 1). Under the chosen substrate conditions (Fig. 2B and D) the following stationary states were maintained: Ca_xE_1 ($x = 1-2$), E_1 , Ca_2E_1 , P-E_2 , $\text{P-E}_2\text{Ca}_2$. The changes of the fluorescence intensity upon substrate additions indicate that especially ion binding or release steps contribute to the electrogenic of the Ca-ATPase. The ATP-induced conformational transition, $\text{E}_1 \rightarrow \text{E}_2$, is accompanied only by a small alteration of the fluorescence ($\Delta F/F_0 \leq 10\%$). The absence of comparable fluorescence changes in control experiments with protein-free lipid vesicles or with enzyme inhibited thermally or by thapsigargin, showed that the observed changes were produced by substrate-specific partial reactions. The effect of high Ca^{2+} concentrations ($>1 \text{ mM}$) will be discussed below.

Although it is not possible to assign dielectric coefficients to the observed reaction steps on the basis of the data presented, it can be concluded that ion movements

between the aqueous phases and the binding sites are the main electrogenic events in the transport of Ca^{2+} by the SR-Ca-ATPase.

CALCIUM-INDUCED EFFECTS

The dependence of the fluorescence decrease as a function of the Ca^{2+} concentration in the E_1 and in the P-E_2 conformation of the Ca-ATPase (Figs. 4 and 5) is in agreement with previously published findings and supports the interpretation that 2BITC reports specific protein functions. Ca^{2+} titration in state E_1 resulted in a fluorescence decrease that could be described by cooperative Ca^{2+} binding which can be fitted by a single Hill curve with an half-saturating concentration, K_M , of 600 ± 50 nM and a Hill coefficient, n , of 2 (Fig. 4B). This result is in agreement with data obtained by binding radioactive Ca^{2+} ions (Inesi et al., 1980) with $1/K_{\text{app}} = 440$ nM and $n = 1.82$. The effect of Ca^{2+} binding on the intrinsic tryptophan fluorescence has been studied under various Mg^{2+} concentrations and pH, and under comparable conditions (1 mM Mg^{2+} , pH 7) half-saturating concentrations of $K_M = 730$ nM ($n = 1.6$) (Forge, Mintz & Guillaín, 1993) and 400 μM (Dupont, 1976) were published.

Upon addition of ATP a sequence of reaction steps occurs spontaneously: enzyme phosphorylation and ion occlusion, conformational transition to E_2 , and release of Ca^{2+} to the luminal side of the ion pump (Fig. 1). The small fluorescence decrease in this partial reaction indicated that no dramatic change of net charge within the protein dielectric could be detected by the fluorescent dye (Figs. 2D and 6). In a standard experiment with thermally inactivated membrane preparations addition of ATP caused a small fluorescence increase of $< +5\%$ (*not shown*) which was comparable to that in the case of thapsigargin-inhibited enzyme (Fig. 3A). Due to the fact that the vesicular membrane preparation is very leaky and that the addition of A23187 and FCCP, which short-circuits the membranes for Ca^{2+} (Yu et al., 1993), did not alter the fluorescence levels in the standard experiment significantly, we may assume that the final Ca^{2+} concentration is the same on both sides of the membrane in the case of the slow equilibrium-titration experiments. In the standard experiment enzyme phosphorylation was performed in the presence of about 50 μM free Ca^{2+} , therefore in state P-E_2 at least one ion-binding site should be free of Ca^{2+} because of the strongly reduced affinity of the sites. Taking all these facts into account the observed small fluorescence decrease in the partial reaction $\text{Ca}_2\text{E}_1 \rightarrow \text{P-E}_2$ (or $\text{P-E}_2\text{Ca}$) provides a strong constraint for modeling the electrogenicity of the transport mechanism (*see* below).

To titrate the Ca^{2+} -binding sites in state P-E_2 , the ion concentrations had to be increased up to 100 mM (Fig. 5).

Ca^{2+} concentrations above 1 mM produced a significant artifact with the dye 2BITC, as could be shown in control experiments with lipid vesicles and with membrane preparations inactivated by thapsigargin or by high-temperature incubation (Fig. 5B). The specific effect of Ca^{2+} binding to the ion pump on the fluorescence intensity could be determined only by subtraction of the non-specific fluorescence decrease from the total fluorescence signal (Fig. 5B). Therefore, the obtained binding affinities of the enzyme in P-E_2 are less precise than all other properties of the SR-Ca-ATPase presented in this study. Two distinct equilibrium dissociation constants for Ca^{2+} , 5 μM and 2.2 mM, have been determined (Fig. 5B). These results may be compared with previously published data. As discussed by Mintz and Guillaín (1997), it is rather difficult to investigate the properties of the luminal calcium sites. In the case of ATP synthesis (by reversal of the SR-Ca-ATPase) an apparent dissociation constant between 300 μM and 1 mM was estimated (Prager et al., 1979; de Meis, Martins & Alves, 1980). Inesi and de Meis (1989) compiled from various sources rate constants for Ca^{2+} binding and release reactions in the P-E_2 state, from which equilibrium constants of 7 mM and 33 mM can be calculated. Considering the methodological uncertainties these values and our findings are in fair agreement. If in future investigations the problem of the Ca^{2+} -induced dye artifact can be solved, the method presented in this paper may provide accurate estimates of the luminal Ca^{2+} binding affinities.

THAPSIGARGIN-INDUCED EFFECTS

Experiments performed either by addition of or in the presence of thapsigargin showed that the inhibitor led to a protein state with the highest fluorescence level detected, which was slightly, but not significantly, higher than that of state E_1 (Fig. 3). This level indicates the lowest amount of positive charge within the ion pumps. If the small effects of substrate additions ($< 5\%$) in standard experiments with thapsigargin-inhibited enzyme (Fig. 3A) are assigned to nonspecific interactions between the charged substrates and the dye then this high fluorescence level could indicate an inhibited state of the Ca-ATPase which is related to state E_1 with empty ion sites blocked for Ca^{2+} binding. This interpretation was suggested by previous studies (*see* Inesi & Sagara, 1992), in which it was demonstrated that thapsigargin forces the enzyme into a 'dead end complex' and inhibits Ca^{2+} binding in the ion sites as well as ATP binding in the nucleotide site.

pH-INDUCED EFFECTS

The effect of protons on the action of the SR-Ca-ATPase has been investigated for a number of years. It has been

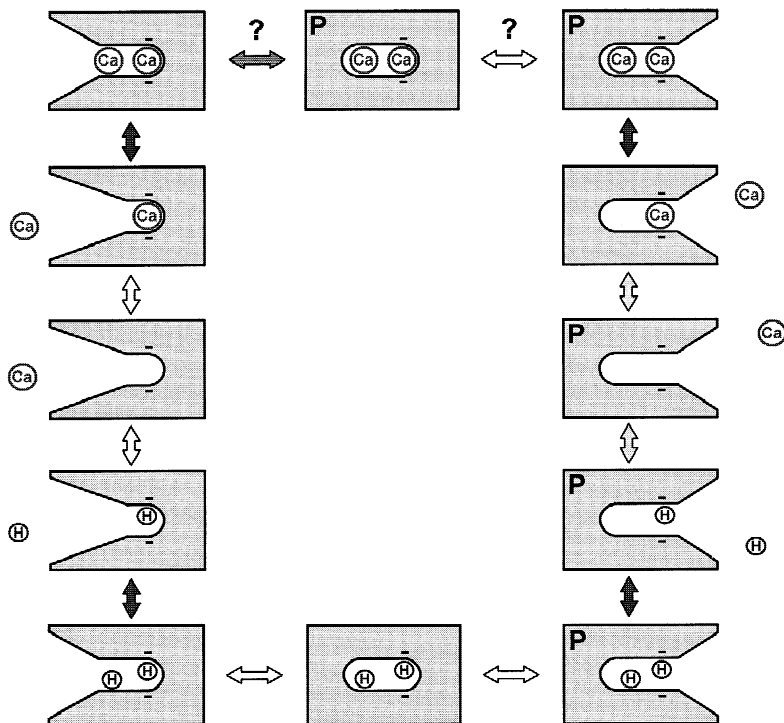

Fig. 9. Electrostatic model of the SR-Ca-ATPase on the basis of the model of Yu et al. (1994). The jaw-like widened access to binding sites symbolize a low electric field condition which does not contribute significantly to an electrogenic reaction step. The darker the arrows between states the more pronounced is the suggested electrogenicity. Question marks indicate possible candidates for electrogenic steps which could not be resolved experimentally so far. We would like to note that the drawing is meant only schematically and does not propose structural concepts.

found that H^+ ions affect Ca^{2+} binding (Forge et al., 1993) and that H^+ ions are transferred as counterions by the ion pump from lumen to cytoplasm (Madeira, 1978; Chiesi & Inesi, 1980) and out of the internal volume of reconstituted vesicles (Yu et al., 1994). The results of experiments on pH effects presented in this paper are consistent with the interpretation that H^+ ions are able to bind in or at least so close to the Ca^{2+} sites that they mutually exclude each other within the binding moiety. This view is supported by the findings that (i) H^+ ions produce fluorescence decreases similar to those of Ca^{2+} when binding was promoted by increasing concentrations, (ii) pH-induced effects on 2BITC are found only under conditions when the binding sites are accessible, i.e., not occupied by saturating Ca^{2+} concentrations, and (iii) the binding affinity for Ca^{2+} can be affected in a way that could be predicted by competition with H^+ ions for the same sites.

Not understood so far is the fluorescence decrease observed in conformation E_1 at pH values above 7 (Fig. 7A). This effect was not observed in state $P-E_2$; therefore, a nonspecific dye artifact may be excluded. The decrease of the fluorescence intensity suggests either an import of positive charge within the protein dielectric or the disappearance of negative charge. Since BAPTA has been used as chelator, a loss of Ca^{2+} -binding capacity at high pH and therefore an increase of free Ca^{2+} concentration can be excluded. Possible explanations could be increased Mg^{2+} binding when the H^+ concentration is low enough, or pH-induced conformational rearrange-

ments of protein structure in which dipoles created by the amino acids could orient in a such a way that a net positive potential is generated inside the transmembrane domains and is detected by the dye. This finding will be investigated in more detail in future investigations.

REFINEMENT OF A MECHANISTIC MODEL

In summary it can be stated that all major fluorescence changes were associated with partial reactions in which ions were moved into or out of the binding sites. On the basis of the presented experimental evidence it is a reasonable assumption that the reactions $E_1 + 2 Ca^{2+} \rightleftharpoons Ca_2E_2$ (as well as $E_1 + 2 H^+ \rightleftharpoons H_2E_2$) and $P-E_2 + 2 Ca^{2+} \rightleftharpoons P-E_2Ca_2$ ($P-E_2 + 2 H^+ \rightleftharpoons P-E_2H_2$) are electrogenic. In Fig. 9 an electrostatic model is presented which is based on the H^+/Ca^{2+} exchange model of the Ca-ATPase as published by Yu et al. (1994).

The observation that the concentration dependence of the electrogenic contribution for the reaction $E_1 + 2 Ca^{2+} \rightleftharpoons Ca_2E_2$ can be described by a single cooperative binding process may be understood on the basis of the strictly sequential binding of Ca^{2+} binding (Inesi, 1987; Inesi, Sumbilla & Kirtley, 1990) in analogy to the ‘‘jaw-closing’’ model of cooperative Ca^{2+} binding by the pump (Tanford, Reynolds & Johnson, 1987). If binding of the first Ca^{2+} ion takes place through a water-filled vestibule (with a high dielectric constant, and therefore not electrogenically), and the subsequent ‘‘jaw-closing’’ creates

the second site to which a second Ca^{2+} binds with very high affinity (Inesi & de Meis, 1989), then only the ‘‘jaw-closing’’ and the second Ca^{2+} binding will contribute to the electrogenicity of this partial reaction, which is then reported by the fluorescent probe. An alternative explanation to this single-file process has been recently proposed by Menguy et al. (1998). They present evidence that the cytoplasmic loop between transmembrane segments M6 and M7, with its negatively charged amino acids is involved in binding of the first Ca^{2+} ion and, upon interaction with the first Ca^{2+} , access to the second binding site within the transmembrane domains of the protein becomes possible. This model is able to explain also the observed concentration dependence of Ca^{2+} binding.

The transition $\text{Ca}_2\text{E}_1 \rightarrow \text{P-E}_2$ seems to generate only a minor contribution to electrogenicity (Fig. 2D). This observation is significantly different from the observation of the ATP-induced fluorescence change in the case of Na,K-ATPase (Fig. 2A) where this reaction step produces the major electrogenic effect in the partial reactions covered by the standard experiment. The fluorescence increase in the order of 80–100% could be explained by the presence of two uncompensated negative charges of the ion-binding sites within the protein dielectric of the Na,K-ATPase (Heyse et al., 1994). Since luminal Ca^{2+} binding to the Ca-ATPase was found to be electrogenic (Fig. 5B), it may be suggested that the transient Ca^{2+} occlusion (and/or the conformation transition) is accompanied by an electrogenic effect which would produce to a fluorescence level similar to that of state $\text{P-E}_2\text{Ca}_2$ which cannot be resolved in the presented equilibrium titration experiments. These apparently differing electrostatic conditions of the P-E_2 states of the SR-Ca-ATPase and the Na,K-ATPase will be subject of further studies.

When luminal Ca^{2+} binding was analyzed, a two step process was found in which binding of the first Ca^{2+} with higher affinity produced a smaller fluorescence decrease than binding of the second (Fig. 5B). This could be explained by the assumption that the site closer to the aqueous phase is more negatively charged than the inner site and therefore more attractive to Ca^{2+} ions. Binding of a second Ca^{2+} would include a single file process in which the first ion bound is pushed into the second site, which is placed deeper in the protein dielectric, to make way for the second ion at the outer, negatively charged site. This process would be expected to cause a stronger electrogenicity with a more pronounced fluorescence decrease than is observed.

Similar arguments would hold for H^+ binding to the sites. Interaction of additional H^+ with negatively charged amino acids in the binding moiety as proposed by Yu et al. (1994) might also occur. If the pK of the side groups is high enough, P-E_2 may actually be a state

in which 2 H^+ are already bound to negative charges close to the mouth of the ‘‘access channel.’’ In Fig. 9 only those H^+ were plotted which are transported. The locations of the protons in state $\text{P-E}_2\text{H}_2$ was assumed to account for the observed single binding isotherm in Fig. 7B. Due to the restricted pH range covered by the experiments this detail is purely speculative.

In this first approach we were able to demonstrate that an experimental technique previously applied to the Na,K-ATPase can be extended to the SR-Ca-ATPase with an analogue dye and that it allowed the determination of electrogenic partial reactions in agreement with the recently published stoichiometry and operational mode of the ion pump.

The authors would like to thank E. Ströbele and P. Koufen for helpful discussions, Christine Peinelt for technical assistance, and Dr. J. Breed for a critical reading of the manuscript. The styryl dye 2BITC was a gift from Prof. H.-D. Martin, University of Düsseldorf. This work was financially supported by the Deutsche Forschungsgemeinschaft (Sonderforschungsbereich 156).

References

- Andersen, J.P. 1989. Monomer-oligomer equilibrium of sarcoplasmic reticulum Ca-ATPase and the role of subunit interaction in the Ca^{2+} pump mechanism. *Biochim. Biophys. Acta* **988**:47–72
- Apell, H.-J. 1997. Kinetic and energetic aspects of the Na^+/K^+ Transport cycle steps. *Ann. N.Y. Acad. Sci.* **834**:221–230
- Apell, H.-J., Bersch B. 1987. Oxonol VI as an optical indicator for membrane potentials in lipid vesicles. *Biochim. Biophys. Acta* **903**:480–494.
- Apell, H.-J., Roudna, M., Corrie, J.E.T., Trentham, D.R. 1996. Kinetics of the phosphorylation of Na,K-ATPase by inorganic phosphate detected by a fluorescence method. *Biochemistry* **35**:10922–10930
- Birmes, M. 1995. Neuartige membranpotentialsensitive Fluoreszenzfarbstoffe mit Styrylpyridiniumchromophor. Ph.D. thesis, University of Düsseldorf, Germany, pp. 1–248
- Bühler, R., Stürmer, W., Apell, H.-J., Läger, P. 1991. Charge translocation by the Na,K-pump: I. Kinetics of local field changes studied by time-resolved fluorescence measurements. *J. Membrane Biol.* **121**:141–161
- Chiesi, M., Inesi, G. 1980. Adenosine 5'-triphosphate dependent fluxes of manganese and hydrogen ions in sarcoplasmic reticulum vesicles. *Biochemistry* **19**:2912–2918
- Clarke, R., Kane, D.J., Apell, H.-J., Roudna, M., Bamberg, E. 1998. Kinetics of Na^+ dependent conformational changes of rabbit kidney Na^+/K^+ -ATPase. *Biophys. J.* **75**:1340–1353
- de Meis, L. 1985. Role of water in processes of energy transduction: Ca^{2+} -transport ATPase and inorganic pyrophosphatase. *Biochem. Soc. Sympos.* **50**:97–125
- de Meis, L., Inesi, G. 1992. Functional evidence of a transmembrane channel within the Ca^{2+} transport ATPase of sarcoplasmic reticulum *FEBS Lett.* **299**:33–35
- de Meis, L., Martins, O.B., Alves, E.W. 1980. Role of water, hydrogen ion and temperature on the synthesis of adenosine triphosphate by the sarcoplasmic reticulum adenosine triphosphatase in the absence of a calcium ion gradient. *Biochemistry* **19**:4252–4261
- Dupont, Y. 1976. Fluorescence studies of the Sarcoplasmic Reticulum. *Biochim. Biophys. Res. Comm.* **71**:544–549
- Fedosova, N.U., Cornelius, F., Klodos, I. 1995. Fluorescent styryl dyes

- as probes for Na,K-ATPase reaction mechanism: Significance of the charge of the hydrophobic moiety of RH dyes. *Biochemistry* **34**:16806–16814
- Forge, C., Mintz, E., Guillain, F. 1993. Ca²⁺-binding to sarcoplasmic reticulum ATPase revisited. *J. Biol. Chem.* **268**:10953–10960
- Grinvald, A., Hildesheimer, R., Farber, I., Anglister, L. 1982. Improved fluorescence probes for the measurement of rapid changes in membrane potential. *Biophys. J.* **39**:301–308
- Grynkiewicz, G., Poenie, M., Tsien, R.Y. 1985. A new generation of Ca²⁺ indicators with greatly improved fluorescence properties. *J. Biol. Chem.* **260**:3440–3450
- Hasselbach, W., Oetliker, H. 1983. Energetics and electrogenicity of the sarcoplasmic reticulum calcium pump. *Annu. Rev. Physiol.* **45**:325–339
- Heilmann, C., Brdiczka, D., Nickel, E., Pette, D. 1977. ATPase activities, Ca²⁺ transport and phosphoprotein formation in sarcoplasmic reticulum subfractions of fast and slow rabbit muscles. *Eur. J. Biochem.* **81**:211–222
- Heyse, S., Wuddel, I., Apell, H.-J., Stürmer, W. 1994. Partial reactions of the Na,K-ATPase: Determination of rate constants. *J. Gen. Physiol.* **104**:197–240
- Inesi, G. 1985. Mechanism of calcium transport. *Annu. Rev. Physiol.* **47**:573–601
- Inesi, G. 1987. Sequential mechanism of calcium binding and translocation in sarcoplasmic reticulum adenosine triphosphatase. *J. Biol. Chem.* **262**:16338–16342
- Inesi, G., de Meis, L. 1989. Regulation of steady state filling in sarcoplasmic reticulum. Roles of back-inhibition, leakage, and slip-page of the calcium pump. *J. Biol. Chem.* **264**:5929–5936
- Inesi, G., Sumbilla, C., Kirtley, M.E. 1990. Relationship of molecular structure and function in the Ca²⁺ transport ATPase. *Physiol. Rev.* **70**:749–760
- Inesi, G., Kurzmack, M., Coan, C., Lewis, D.E. 1980. Cooperative calcium binding and ATPase activation in sarcoplasmic reticulum vesicles. *J. Biol. Chem.* **255**:3025–3031
- Inesi, G., Sagara, Y. 1992. Thapsigargin, a high affinity and global inhibitor of intracellular Ca²⁺ transport ATPases. *Arch. Biochem. Biophys.* **298**:313–317
- Kane, D.J., Fendler, K., Grell, E., Bamberg, E., Taniguchi, K., Froehlich, J.P., Clarke, R.J. 1997. Stopped-flow kinetic investigations of the conformational changes of pig kidney Na⁺,K⁺-ATPase. *Biochemistry* **36**:13406–13420
- Klodos, I., Forbush III, B. 1988. Rapid conformational changes of the Na/K⁺ pump revealed by a fluorescent dye, RH 160. *J. Gen. Physiol.* **92**:46a
- Läuger, P. 1991. *Electrogenic Ion Pumps*. pp. 226–251. Sinauer, Sunderland, MA
- Läuger, P., Apell, H.-J. 1986. A microscopic model for the current-voltage behaviour of the Na,K-pump. *Eur. Biophys. J.* **13**:309–321
- Loew, L.M., Scully, S., Simpson, L., Waggoner, A.S. 1979. Evidence for a charge-shift electrochromic mechanism in a probe of membrane potential. *Nature* **281**:497–499
- Madeira, V.M.C. 1978. Proton gradient formation during transport of Ca²⁺ by sarcoplasmic reticulum. *Arch. Biochem. Biophys.* **185**:316–325
- Markwell, M.A.K., Haas, S.M., Bieber, L.L., Tolbert, N.E. 1978. A modification of the lowry procedure to simplify protein determination in membrane and lipoprotein samples. *Analyt. Biochem.* **87**:206–210
- Menguy, T., Corre, F., Boneau, L., Dechamps, S., Møller, J.V., Champeil, P., le Maire, M., Falson, P. 1998. The cytoplasmic loop located between transmembrane segments 6 and 7 controls activation by Ca²⁺ of sarcoplasmic reticulum Ca²⁺-ATPase. *J. Biol. Chem.* **273**:20134–20143
- Mintz, E., Guillain, F. 1997. Ca²⁺ transport by the sarcoplasmic reticulum ATPase. *Biochim. Biophys. Acta* **1318**:52–70
- Prager, R., Punzengruber, C., Kolassa, N., Winkler, F., Suko, J. 1979. Ionized and bound calcium inside isolated sarcoplasmic reticulum of skeletal muscle and its significance in phosphorylation of adenosine triphosphatase by orthophosphate. *Eur. J. Biochem.* **97**:239–250
- Pratap, P., Palit, A., Grassi-Nemeth, E., Robinson, J.D. 1996. Kinetics of conformational changes associated with potassium binding to and release from Na⁺/K⁺-ATPase. *Biochim. Biophys. Acta* **1285**:203–211
- Sagara, Y., Inesi, G. 1992. *J. Biol. Chem.* **266**:13503–13506
- Schefer, U., Aumann, D., Pretsch, E., Oesch, U., Simon, W. 1986. Neutral carrier based Ca²⁺-selective electrode with detection limit in the sub-nanomolar range. *Anal. Chem.* **58**:13270–13274
- Schwartz, A., Nagano, K., Nakao, M., Lindenmayer, G.E., Allen, J.C. 1971. The sodium- and potassium-activated adenosine triphosphatase system. *Methods Pharmacol.* **1**:361–388
- Stürmer, W., Apell, H.-J. 1992. Fluorescence study on cardiac glycoside binding to the Na,K-pump: Ouabain binding is associated with movement of electrical charge. *FEBS Lett.* **300**:1–4
- Stürmer, W., Bühler, R., Apell, H.-J., Läuger, P. 1991. Charge translocation by the Na,K-Pump: II. Ion binding and release at the extracellular face. *J. Membrane Biol.* **121**:163–176
- Tanford, C., Reynolds, J.A., Johnson, E.A. 1987. Sarcoplasmic reticulum calcium pump: A model for Ca²⁺ binding and Ca²⁺-coupled phosphorylation. *Proc. Natl. Acad. Sci. USA* **84**:7094–7098
- Vilsen, B. 1995. Structure-function relationships in the Ca²⁺-ATPase of sarcoplasmic reticulum studied by use of the substrate analogue CrATP and site-directed mutagenesis. Comparison with the Na⁺K⁺-ATPase. *Acta Physiol. Scand.* **154** Suppl. **624**:1–146
- Vilsen, B., Ramlov, D., Andersen, J.P. 1997. Functional consequences of mutations in the transmembrane core region for cation translocation and energy transduction in the Na⁺K⁺-ATPase and the SR Ca²⁺-ATPase. *Annals NY Acad. Sci.* **834**:297–309
- Walz, D., Caplan, S.R. 1988. Energy coupling and thermokinetic balancing in enzyme kinetics. Microscopic reversibility and detailed balance revisited. *Cell Biophys.* **12**:13–28
- Yu, X., Carroll, S., Rigaud, J.-L., Inesi, G. 1993. H⁺ countertransport and electrogenicity of the sarcoplasmic reticulum Ca²⁺ pump in reconstituted proteoliposomes. *Biophys. J.* **64**:1232–1242
- Yu, X., Hao, L., Inesi, G. 1994. A pK change of acidic residues contributes to cation countertransport in the Ca²⁺-ATPase of sarcoplasmic reticulum. *J. Biol. Chem.* **269**:16656–16661
- Yu, X., Inesi, G. 1995. Variable stoichiometric efficiency of Ca²⁺ and Sr²⁺ transport by sarcoplasmic reticulum ATPase. *J. Biol. Chem.* **270**:4361–4367
- Zhang, P., Toyoshima, C., Yonekura, K., Green, N.M., Stokes, D.L. 1998. Structure of the calcium pump from sarcoplasmic reticulum at 8-Å resolution. *Nature* **392**:835–839