

The *ftsH* Gene of *Bacillus subtilis* Is Transiently Induced after Osmotic and Temperature Upshift

ELKE DEUERLING, BETTINA PAESLACK, AND WOLFGANG SCHUMANN*

Institute of Genetics, University of Bayreuth, D-95440 Bayreuth, Germany

Received 8 November 1994/Accepted 27 April 1995

The *ftsH* gene of *Bacillus subtilis* has been identified as a salt-sensitive insertion mutation in strain UG1. Here, we show that UG1 has an insertion near the 3' end of *ftsH*. The salt sensitivity of this mutant was caused by reduction of *ftsH* mRNA levels by the synthesis of an artificial antisense RNA originating at a promoter located within the insertion and reading backwards into the *ftsH* gene. The salt-sensitive phenotype could be overcome by deleting the promoter from which the antisense RNA was transcribed. A physiological analysis of the isogenic wild-type strain in minimal medium revealed unimpaired growth at up to 1 M NaCl, and growth above 1.2 M NaCl was observed only after addition of the osmoprotectant proline or glycine betaine. In contrast, growth of strain UG1 was reduced at a salt concentration above 0.2 M, which could be rescued by the two compatible solutes already mentioned and also by trehalose. Primer extension revealed one potential transcription start site downstream of a putative vegetative promoter, which was activated after osmotic or temperature upshift. Northern (RNA blot) experiments led to the detection of a 2.1-kb transcript, suggesting that *ftsH* is monocistronic. A transcriptional fusion between *ftsH* and the *gus* reporter gene exhibited a twofold increase in β -glucuronidase activity after osmotic upshift. To further confirm the need for an enhanced level of FtsH protein after osmotic upshift, the promoter was replaced by the sucrose-inducible promoter P_{sacB} . Whereas this mutant strain could grow in the absence of inducer in LB medium, it stopped growth immediately after addition of 1.1 M NaCl. We conclude that an increased amount of FtsH protein is essential for *B. subtilis* to cope with an increase in osmolarity or temperature.

Bacteria have evolved sophisticated mechanisms that enable them to survive a variety of environmental stresses, including oxidative stress, extreme pH, anaerobiosis, heat shock, osmotic shock, and starvation. They respond to these various stimuli by changing the expression of groups of genes termed stress genes, which encode specific sets of proteins that are characteristic of each stress (11). These proteins are thought to be important for adaptation to the new environment as well as for protection against future potentially lethal exposures to that stress. Understanding how these genes are regulated is fundamental to a comprehensive knowledge of cellular stress adaptation.

Exposure of bacteria to high osmolarity leads to dehydration, collapse of ion gradients over the cytoplasmic membrane, and decrease in cell viability. Therefore, the first response of bacteria to osmotic stress consists of changes in the activities of enzymes and of transport systems so that the turgor pressure is restored and the cytoplasmic environment is optimized. Somewhat later, changes in gene expression provide additional flexibility in adapting cells to upshock (for reviews, see references 7, 8, and 13). The regulation of gene expression in response to changing levels of osmolarity requires a sensor function to monitor increased levels of the osmotically active substance and an effector function to mediate a transcriptional and/or translational response. The molecular nature of both functions in eubacteria has still to be disclosed.

There are only a few publications dealing with osmotic upshock and the induction of stress proteins in *Bacillus subtilis*. After hypersaline treatment, the turgor pressure decreased, and subsequent recovery was K^+ dependent (43). Thereafter,

B. subtilis has been shown to accumulate proline, and proline synthesis appeared to be dependent on the prior accumulation of K^+ (25). In cells upshocked in medium enriched in glycine betaine, the endogenous synthesis of proline was repressed and glycine betaine served as the sole organic osmoticum (44). Boch and coworkers reported that *B. subtilis* can synthesize glycine betaine from exogenously provided choline (5). In addition, salt stress turned out to be very effective in the induction of general as well as specific stress proteins (13, 40, 41).

Recently, we have reported the isolation of a salt-sensitive insertion mutant in which the insertion turned out to affect an open reading frame (ORF) exhibiting significant homology to the *ftsH* genes of *Escherichia coli* (38) and *Lactococcus lactis* (26). The objective of the present study was to carry out an extensive physiological and transcriptional analysis of the *ftsH* locus in both the wild type and its isogenic insertion mutant and to find out why the mutant could not grow under high-salt conditions. During our analysis, we also found that *ftsH* is transiently induced by heat. A possible role for the FtsH protein during stress is discussed.

MATERIALS AND METHODS

Bacterial strains, plasmids, and growth conditions. The bacterial strains and plasmids used are given in Table 1. Bacteria were routinely grown aerobically at 37°C in Luria broth (LB). Spizizen minimal medium (SMM) has been described (35). Ampicillin and chloramphenicol were added at a concentration of 50 and 5 $\mu\text{g ml}^{-1}$, respectively.

DNA manipulations and analysis. Standard methods were used for DNA isolation, restriction endonuclease analyses, and ligation (31). Restriction enzymes, T4 DNA ligase, and alkaline phosphatase were purchased from New England Biolabs, Stratagene, and Boehringer Mannheim and used as recommended by the suppliers. Digoxigenin (DIG)-[11]-ddUTP and the DIG detection kit were purchased from Boehringer Mannheim. Nucleotide sequences were determined by the dideoxy nucleotide chain termination method (32).

Deletion of P_{Tr} and determination of the insertion site of the pJH101 plasmid

* Corresponding author. Mailing address: Institute of Genetics, University of Bayreuth, P.O. Box 10 12 51, D-95440 Bayreuth, Germany. Phone: (49) 921 552708. Fax: (49) 921 552535. Electronic mail address: Wolfgang.Schumann@Uni-Bayreuth.De.

TABLE 1. Bacterial strains and plasmids

Strain or plasmid	Characteristics	Source or reference
<i>E. coli</i> DH5 α	<i>endA1 gyrA96 hsdR17 ϕ80lacZΔM15 supE44 deoR thi-1 Δ(lacZYA-argF)U169 relA1</i>	12
<i>B. subtilis</i>		
1012	<i>leuA8 metB5 r_M⁻ m_M⁺</i>	30
UG1	1012 with insertion of pJH101 at <i>ftsH</i>	10
ED1	1012 with insertion of pUG1E at <i>ftsH</i>	This work
ED2	1012 with a promoterless <i>gus</i> at the <i>amyE</i> locus	This work
ED3	1012 with a transcriptional <i>ftsH-gus</i> fusion at the <i>amyE</i> locus	This work
ED10	1012 in which the promoter region of <i>ftsH</i> had been replaced by a <i>cat</i> -P _{sacB} cassette	This work
Plasmids		
pACYC177	Ap ^r Km ^r	6
pUC18	Ap ^r	46
pBM4	Cm ^r	21
pMKL83	Ap ^r Km ^r	18
pBluescriptKS ⁺	Ap ^r	Stratagene
pUG1E	Chromosomal DNA of UG1 cut with <i>Eco</i> RI and self-ligated	This work
pED02	pMKL83 carrying a transcriptional <i>ftsH-gus</i> fusion	This work
pED05	3.6-kb <i>Hind</i> III chromosomal DNA fragment cloned into pACYC177	This work
pED1113	pUC18 with a <i>cat</i> marker and P _{sacB} sandwiched between up- and downstream sequences of P _A of <i>ftsH</i>	This work
pED Δ F	Internal <i>Sst</i> I- <i>Hind</i> III fragment of <i>ftsH</i> cloned into pBluescriptKS ⁺	This work

within the bacterial chromosome of strain UG1. Strain UG1 contains the integration vector pJH101 inserted near the 3' end of the *ftsH* gene. pJH101 is a derivative of pBR322, which contains a *cat* gene for selection in *B. subtilis* (9). To delete P_{Tc} from UG1, the chromosomal DNA of UG1 was digested with *Eco*RI, the resulting fragments were self-ligated and transformed into *E. coli* DH5 α , and transformants were selected on LB plates containing ampicillin. The recombinant plasmid isolated from one of these transformants was designated pUG1E and lacked the P_{Tc} promoter (Fig. 1A). This plasmid was used to transform *B. subtilis* 1012, and integrants were selected on LB plates containing chloramphenicol. One such strain was named ED1, and the correct insertion of pUG1E within the *ftsH* gene was confirmed by Southern blotting (data not shown). The insertion site of pJH101 within *ftsH* was determined by DNA sequencing with pUG1E.

Construction of a transcriptional fusion between *ftsH* and *gus*. To monitor expression of the *ftsH* gene, a region upstream of the *ftsH* structural gene was transcriptionally fused to the *gus* reporter gene and integrated at the *amyE* locus of the *B. subtilis* chromosome. To accomplish this goal, a 299-bp fragment

corresponding to nucleotides 29 to 327 in Fig. 2B was generated through PCR amplification. A *Hind*III and a *Bam*HI site were introduced at the 5' end and the 3' end, respectively. The *Hind*III and *Bam*HI double-digested fragment was then inserted into *Hind*III-*Bam*HI-digested pMKL83 upstream of the *gus* gene. This vector carries a cassette consisting of a promoterless *gus* gene and a *cat* marker sandwiched between the two halves of the *amyE* locus, allowing integration of the whole transcriptional fusion at the chromosomal *amyE* locus by a double crossover event (18), resulting in strain ED3. Integration of the *ftsH:gus* operon fusion at *amyE* was verified by PCR with oligonucleotides from the two inside ends of the split *amyE* locus. Chromosomal DNA from an integrant with the promoterless *gus* gene served as a control (strain ED2). The activity of the *gus* gene (which encodes β -glucuronidase) was measured as described before with *p*-nitrophenyl- β -D-glucuronide as the substrate (17).

Construction of pED1113 and P_{sacB}-*ftsH*. Plasmid pED1113 was designed to replace the chromosomal *ftsH* with a modified *ftsH* gene. The expression of this modified *ftsH* gene was controlled by the inducible promoter from *sacB*, a structural gene for levansucrase. To replace the vegetative promoter P_A by the controllable P_{sacB}, DNA fragments of about 500 bp each up- and downstream of the vegetative promoter were generated by PCR. Both amplicons were used to flank a cassette consisting of a *cat* gene followed by P_{sacB}. Figure 2A depicts the genomic organization of the *ftsH* gene. To amplify the upstream region, oligonucleotides ON1 (5'-GGCCATGCATGCGTATCAAGATAACATTTCC GTTG GC-3'; *Sph*I recognition site underlined) and ON2 (5'-GGCCATCTG CAGGGCTGCCGATCAGCTTTCATAAAC-3'; *Pst*I) were used, resulting in a 487-bp amplicon. To generate the downstream region of P_A, oligonucleotides ON3 (5'-GGCCATGGTACCGTGCTTACTGTGGGAGGAGGTAAG-3'; *Kpn*I) and ON4 (5'-GTTTACC GG TACCCGGAGG-3') were used as primers, resulting in a 661-bp amplicon. The approximate locations of ON1 and ON4 are shown in Fig. 2A; the exact locations of ON2 and ON3 are shown in Fig. 2B. The cassette was recovered as a 1.8-kb *Pst*I-*Kpn*I fragment from pBM4 (21) and inserted into pUC18. The *Sph*I-*Pst*I double-digested fragment was inserted upstream and the *Kpn*I-*Sst*I double-digested fragment was inserted downstream of the cassette (there is an *Sst*I recognition site immediately upstream of ON4). This plasmid was used to transform *B. subtilis* 1012. Chloramphenicol-resistant colonies were selected and verified for the replacement of P_A by P_{sacB} by PCR with oligonucleotides ON1 and ON4. The resulting strain was designated ED10, and the situation at the *ftsH* locus is shown in Fig. 8A.

Analyses of transcription. Isolation of total RNA, Northern analyses, and primer extension were performed as described previously (42). The following synthetic oligonucleotides complementary to the noncoding strands were used as hybridization probes: ON5 (5'-CACGTTTCATCGTGTCCC-3'; internal part of *ftsH*) and ON6 (5'-AGTAGCTACAACCCCG-3'; 5' end of *ftsH*). These oligonucleotides were labeled at their 5' termini with DIG-[11]-ddUTP as described previously (47). To detect *ftsH* antisense RNA, a DIG-labeled RNA probe was synthesized in vitro with T7 RNA polymerase (Boehringer Mannheim) from the linearized plasmid pED Δ F. To construct this plasmid, a 3.6-kb *Hind*III fragment of chromosomal *B. subtilis* DNA containing most of the *ftsH* gene (27) was first cloned into pACYC177, resulting in pED05. In a second step, the internal 1.1-kb *Sst*I-*Hind*III *ftsH* fragment was recovered from pED05 and cloned into pBluescriptKS⁺.

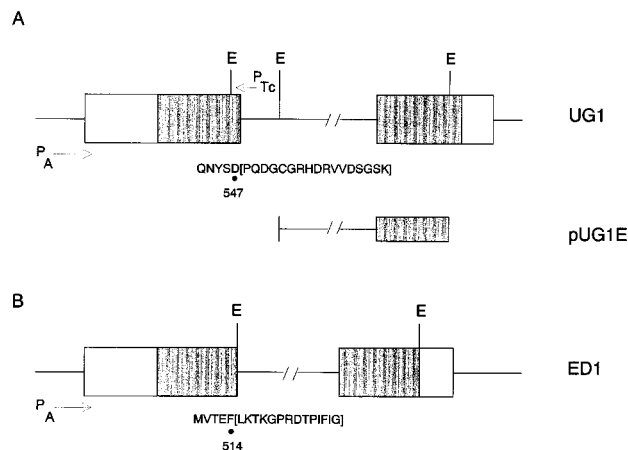

FIG. 1. Schematic representation of two *ftsH* insertion mutants. (A) Strain UG1 contains an insertion of the integration vector pJH101 (10). In pUG1E, the DNA sequences between the *Eco*RI and *Bam*HI sites of pJH101 have been deleted, removing P_{Tc}. (B) Strain ED1 was obtained by integration of pUG1E. The DNA sequences of *ftsH* which have been duplicated because of the insertion of the recombinant plasmids are drawn as hatched boxes. Below the *ftsH* gene, the five C-terminal amino acid residues of the truncated FtsH protein are given, followed by the fused foreign amino acid residues (in brackets) encoded by the plasmid; the last amino acid residue of the FtsH protein is indicated by a dot. The complete FtsH protein consists of 637 amino acid residues. P_A, vegetative promoter; P_{Tc}, tetracycline resistance promoter; E, *Eco*RI.

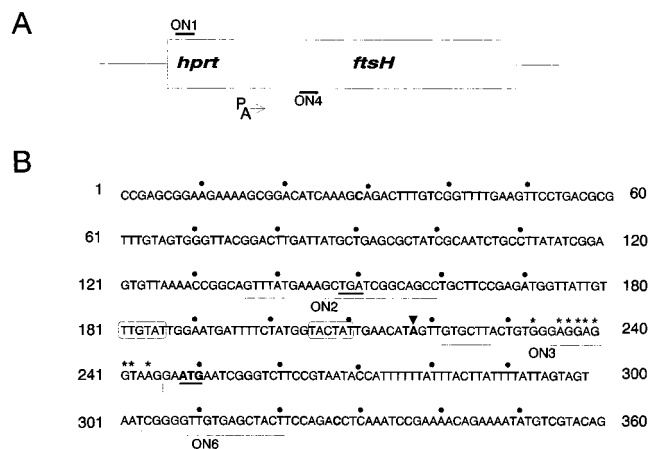

FIG. 2. Nucleotide sequence of the intergenic region between *hpert* and *ftsH*. (A) Map of the *ftsH* locus. P_A, vegetative promoter; ON1 and ON4 denote the locations of the two oligonucleotides which have been used to amplify the upstream and downstream regions of P_A (see Materials and Methods). (B) DNA sequences of the intergenic *hpert-ftsH* region. Indicated are the putative Shine-Dalgarno sequence (asterisks above the DNA sequence) and the potential vegetative promoter (the -35 and -10 regions are boxed); the stop codon of *hpert* and the start codon of *ftsH* are given in boldface and are underlined. The 5' end of mRNA as identified by primer extension is indicated by a boldface letter and by an arrow. The positions of oligonucleotides ON2 and ON3, used to replace the promoter, and of ON6, used for primer extension, are indicated.

RESULTS

Failure of strain UG1 to grow under high salt concentrations overcome by deleting a promoter reading backwards into the *ftsH* gene. Recently, we published the isolation of the salt-sensitive insertion mutant UG1 (10), in which the pBR322 derivative pJH101 (9) has been integrated near the 3' end of an ORF. Integration was accomplished by first creating a *Sau3AI* fragment library of chromosomal *B. subtilis* DNA in pJH101 and then transforming the recombinant plasmids into *B. subtilis* 1012. Insertion of the whole plasmid occurred by Campbell-type integration. It turned out that in UG1, the insertion affected an ORF exhibiting significant homology to the *ftsH* genes of *E. coli* (38) and *L. lactis* (26). Recently, the complete sequence of the *B. subtilis ftsH* gene has been published as part of the *B. subtilis* genome sequencing project (27).

First, the insertion site of pJH101 within the *ftsH* gene of UG1 was determined as described under Materials and Methods. It turned out that the 90 C-terminal codons of *ftsH* have been replaced by 17 foreign plasmid-carried codons (Fig. 1A). Furthermore, we could deduce from the DNA sequences flanking the insertion site that this mutant resulted from the cloning of an internal 875-bp *Sau3AI* fragment of *ftsH* into pJH101; as a result of the integration, this 875-bp DNA sequence became duplicated (see Fig. 1A).

In contrast to the wild-type strain, the insertion mutant UG1 did not form colonies under high-salt conditions. To explain this behavior, we envisaged three possibilities: (i) the FtsH protein modified at its C terminus is inactive under these conditions; (ii) transcription of the *ftsH* gene is impaired by the P_{Tc} promoter located near the insertion site and reading towards the 5' end of *ftsH* (see Fig. 1A; it has been reported that this promoter is active in *B. subtilis* [19]); and (iii) a combination of both possibilities. To distinguish between these alternatives, we decided to delete the P_{Tc} promoter from the chromosome, resulting in strain ED1. Insertion of the plasmid within ED1 took place between codons 514 and 515 of the *ftsH*

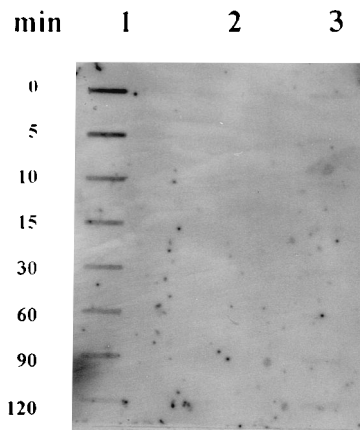

FIG. 3. Detection of antisense RNA. Slot-blots of total RNA of three different strains were done before (0 min) and 5, 10, 15, 30, 60, 90, and 120 min after osmotic shock. DIG-labeled riboprobe RNA was used as the hybridization probe. RNA (0.5 µg) from strains UG1 (lane 1), 1012 (lane 2), and ED1 (lane 3) was tested.

gene. As a result, the last 123 C-terminal codons have been replaced by 14 foreign plasmid-derived codons (Fig. 1B).

In contrast to UG1, cells of ED1 could form colonies on LB plates containing 1.2 M NaCl. This phenotype indicates that the 123 C-terminal amino acid residues are dispensable for growth under these conditions. It furthermore suggests that the failure of strain UG1 to grow under high-salt conditions is related to the P_{Tc} promoter, which could initiate the production of antisense RNA. Therefore, we attempted to demonstrate antisense RNA.

Insertion mutant UG1 synthesizes antisense RNA complementary to the *ftsH* mRNA. Total RNA isolated from UG1, ED1, and wild-type *B. subtilis* was hybridized to DIG-labeled riboprobe RNA complementary to the hypothetical *ftsH* antisense RNA before and at different times after osmotic shock. As can be seen from Fig. 3, a specific signal could be detected, which decreased slowly after the addition of salt (lane 1). This signal could not be detected in either the wild-type strain or the insertion mutant ED1, in which P_{Tc} had been deleted (Fig. 3, lanes 2 and 3). We conclude from these results that P_{Tc} is active in UG1 and that the RNA originating at this promoter most probably acts as antisense RNA, thereby lowering the amount of *ftsH* RNA active in translation. Whereas the production of antisense RNA did not impair growth in the absence of salt, it prevented growth after osmotic upshock, suggesting that the amount of FtsH protein is crucial under these conditions. Although it is rather unlikely, we cannot rigorously exclude the possibility that it is related to the C terminus of the FtsH protein, which is different in the two insertion mutants.

Physiological analysis of wild-type *B. subtilis* 1012 and insertion mutant UG1 in response to salt stress. In contrast to *B. subtilis* 1012, strain UG1 did not grow in medium containing a high concentration of NaCl (10). To substantiate this growth defect in more detail and to find out whether it could be rescued by the addition of osmoprotectants, a detailed analysis of the growth characteristics was carried out in SMM.

First, we analyzed the growth of *B. subtilis* 1012 in the presence of various concentrations of NaCl with and without three different organic compounds known from *E. coli* to act as compatible solutes. In the absence of an osmoprotectant, growth was slightly diminished at up to 1 M NaCl, a severe reduction occurred at 1.1 M, and growth stopped completely at higher concentrations (Fig. 4A). Addition of a compatible sol-

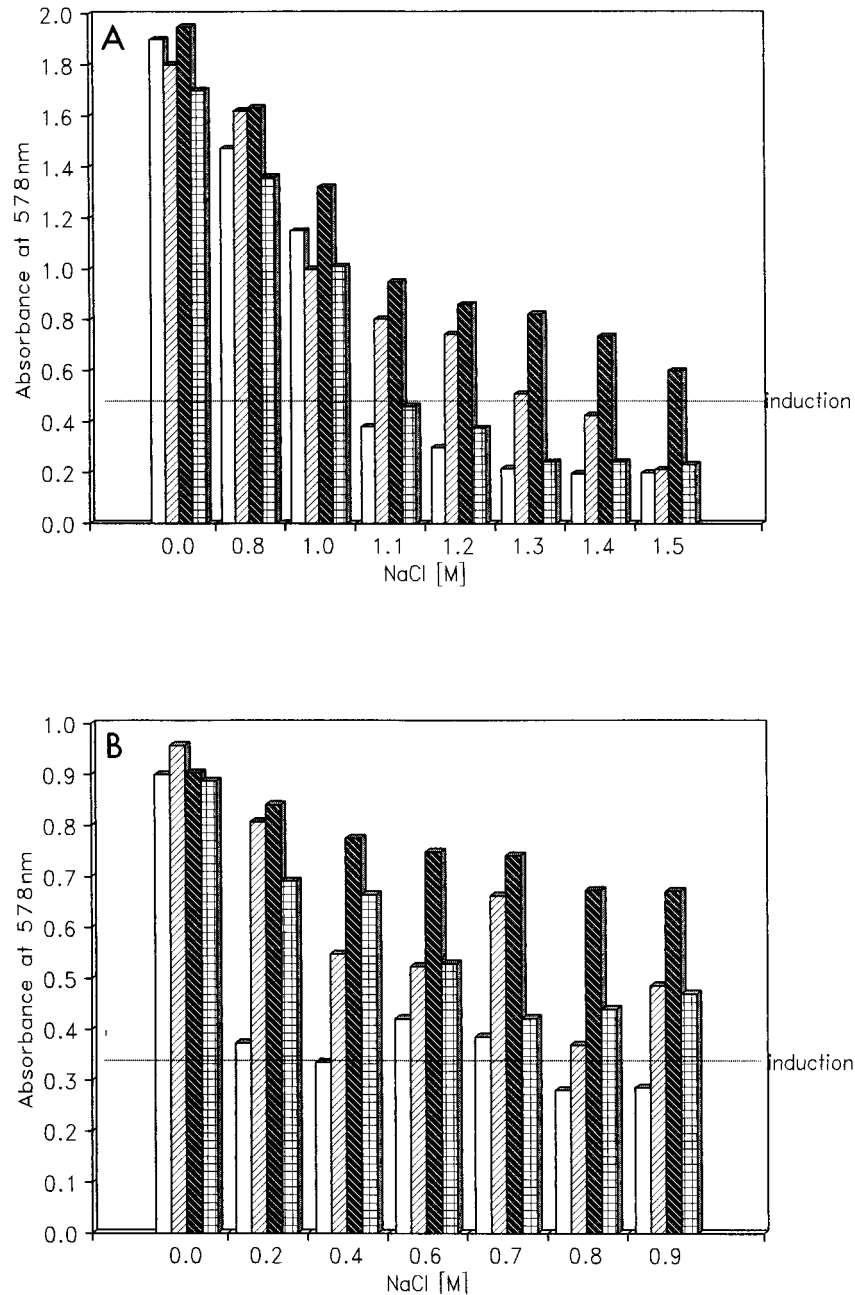

FIG. 4. Growth of two *B. subtilis* strains in the presence of increasing concentrations of NaCl and after addition of three different compatible solutes. The cells were grown in SMM to early log phase, and then NaCl was added (marked by induction) to the final concentration indicated. One culture received no NaCl treatment. The salt-treated cultures were split into four portions; three received an osmoprotectant to a final concentration of 1 mM. The growth of the cultures was monitored by measuring the optical density at 578 nm, and the values after 15 h of growth are given. (A) Wild-type *B. subtilis* 1012; (B) *B. subtilis* UG1. For each set of four bars, growth was measured in the presence of salt alone (□) and after addition of 1 mM proline (▨), glycine betaine (■), or trehalose (▩).

ute affected growth differentially. Whereas trehalose had no influence, both proline and glycine betaine promoted growth. At an NaCl concentration of 1.5 M, glycine betaine still allowed growth, whereas proline had no effect (Fig. 4A).

Next, the insertion mutant UG1 was analyzed. In contrast to its isogenic wild-type strain, growth was already impaired after addition of 0.2 M NaCl (Fig. 4B). At a concentration of 0.8 M NaCl, growth was completely inhibited. Addition of each of the three compatible solutes promoted growth in the presence of NaCl up to 0.9 M. In comparison to the results with the wild-

type strain, glycine betaine turned out to be the most active osmoprotectant, but with UG1, even trehalose promoted growth. Since trehalose was not active in *B. subtilis* 1012, we interpret its effect on UG1 as being indirect. It is known that trehalose has protective properties on proteins and membranes and as such increases the stress tolerance of a variety of organisms (3, 39). The growth of strain ED1 turned out to be comparable to that of *B. subtilis* 1012 (data not shown).

Transcriptional analysis of the *ftsH* gene. The results of the physiological analyses suggested that the *ftsH* gene might be

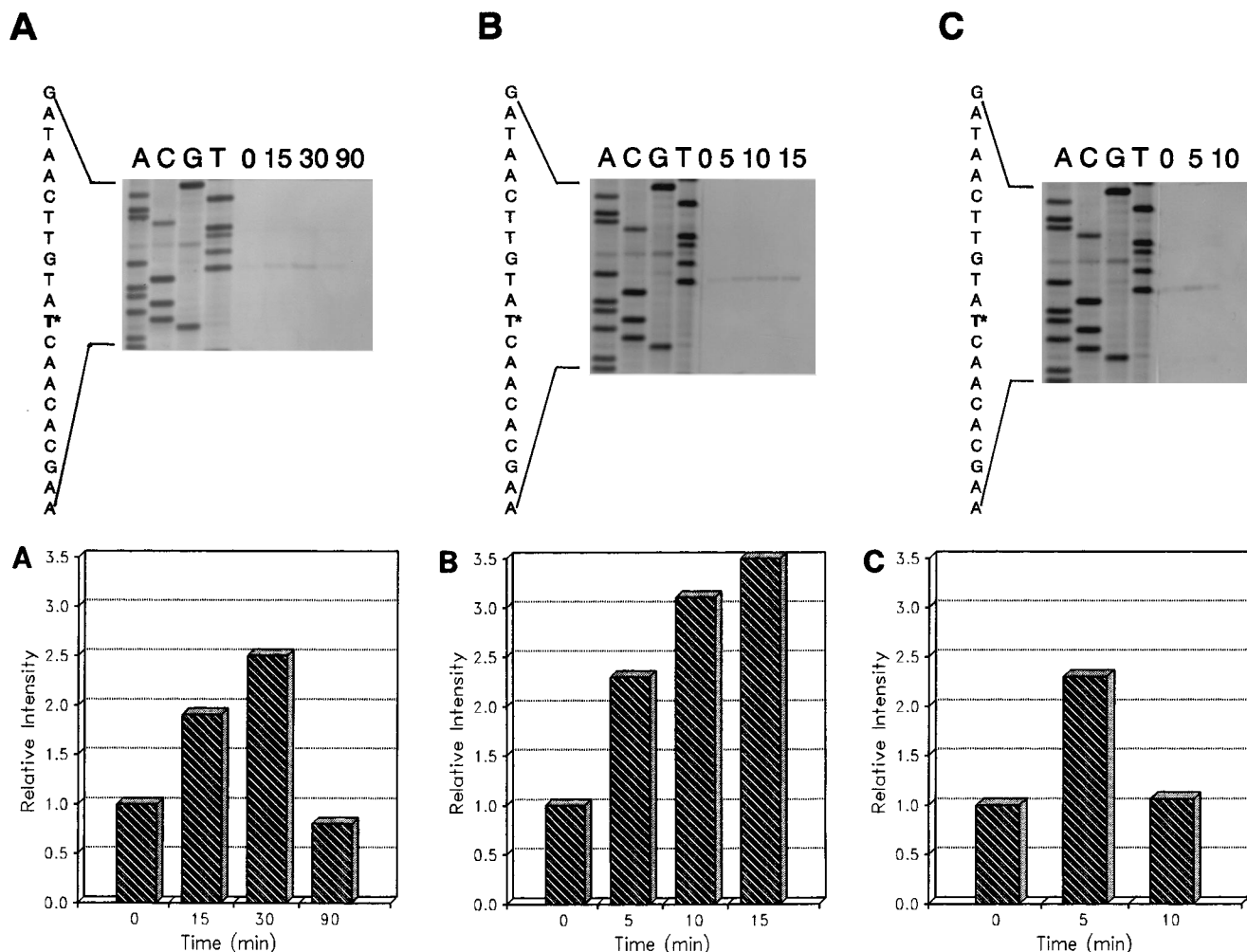

FIG. 5. Mapping of the 5' end of the *ftsH* mRNA by primer extension with ON6. Equal amounts of RNA (10 μ g) were isolated from *B. subtilis* 1012 before (0 min) and at the times indicated after osmotic or temperature shock. RNA was from cells treated with 0.8 M NaCl (A), 10% glucose (B), and heat (C). The potential startpoints are marked by asterisks. Lanes A, C, G, and T show the dideoxy sequencing ladder obtained with the same primer (ON6) with pED05 as the template. For the graphs corresponding to each panel, the amount of primer extension product was quantified by densitometric scanning.

osmoregulated. First, the amount of mRNA was measured before and after osmotic shock in the wild-type strain by slot-blotting and revealed a transient increase in the amount of *ftsH*-specific mRNA (data not shown). This induction was *ftsH* specific, because the level of *xynA* mRNA, which served as an internal control, did not change (data not shown). The *xynA* gene encodes β -xylanase, which is synthesized constitutively during exponential growth (22).

To substantiate this finding and to map the potential transcription start site(s), primer extension experiments were carried out. Total RNA was hybridized with ON6, complementary to the noncoding strand at the beginning of *ftsH* (see Fig. 2B), and extended with reverse transcriptase. One potential transcription start was mapped, starting with an A at the level of mRNA; this signal changed in intensity after osmotic shock by NaCl or by glucose (Fig. 5A and B). This start site is within the appropriate distance from a potential σ^A -dependent promoter (Fig. 2B). As can be seen from the densitometric scanning of the primer extension products, the highest level of *ftsH*-specific mRNA was reached about 30 min after addition of 0.8 M NaCl (Fig. 5A) and increased for at least 15 min after addition of

10% glucose (Fig. 5B). It is interesting that no additional start site was activated after osmotic shock.

Since we have observed that growth of strain UG1 was strongly impaired at 52°C (it stopped growth immediately after heat induction and did not resume growth for at least 13 h; data not shown), we asked whether *ftsH* also becomes induced after a temperature upshift. The primer extension experiment revealed a transient increase by a factor of about 2.5 and furthermore a potential transcription start site that did not change after heat shock (Fig. 5C). A 2.5-fold induction in the amount of FtsH protein has also been reported for the *ftsH* gene of *E. coli* (16). These results indicate that a transiently increased expression of the *ftsH* gene is also essential for the cells to survive heat stress.

To further confirm the transient induction of the *ftsH* gene by an independent experiment, a transcriptional fusion between *ftsH* and the promoterless *gus* gene was constructed and integrated at the *amyE* locus (Fig. 6A), resulting in strain ED3. Strain ED2 served as a control; it carries the promoterless *gus* gene integrated at the *amyE* locus. Whereas the control strain exhibited no *gus* activity, the reporter gene in strain ED3 was

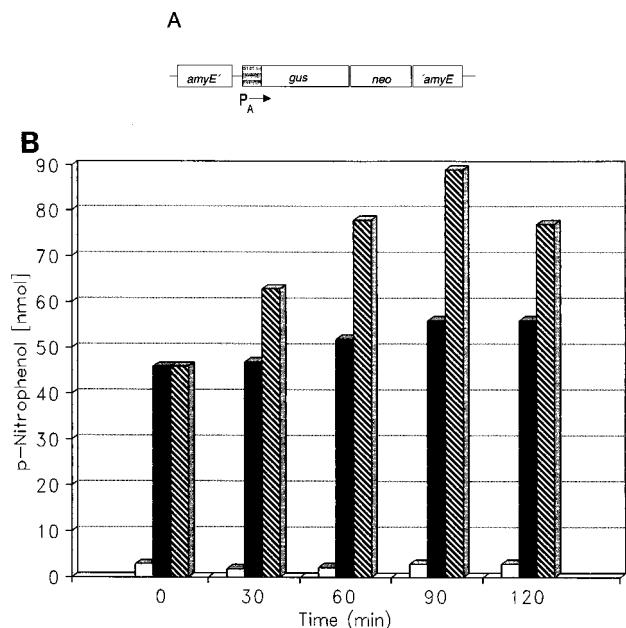

FIG. 6. β -Glucuronidase activity of a transcriptional *ftsH-gus* fusion. Strains ED2 (control, promoterless *gus*) and ED3 (*ftsH::gus* fusion) were grown in SMM to mid-log phase (time zero) and then split into two. One half was further incubated in the absence of osmotic stressor, and the other half was challenged with 10% glucose. Open bars, ED2; solid bars, ED3, no inducer; hatched bars, ED3, 10% glucose.

expressed, resulting in 40 to 50 nmol of *p*-nitrophenol (Fig. 6B). After an osmotic upshift with 10% glucose, the β -glucuronidase activity increased by a factor of about 2, resulting in the production of 90 nmol of *p*-nitrophenol. These results are in agreement with the previous findings that the promoter preceding the *ftsH* gene can be osmotically induced.

From the published sequence of the *ftsH* gene (27), we deduced a potential σ^A -dependent promoter preceding *ftsH* and a putative factor-independent transcription terminator sequence downstream of the gene. Therefore, we suspected that *ftsH* is monocistronic. To prove this hypothesis, Northern blots were performed, which revealed two RNA species with molecular sizes of about 2.1 and 1.5 kb (Fig. 7). The 2.1-kb species dominated and could correspond by length to the complete *ftsH* gene. The smaller species could either result from premature termination within *ftsH*, represent a degradation product of the larger species, or be an unspecific signal. Since we detected a signal of about 1.5 kb in all of our Northern blots dealing with different *B. subtilis* genes, we consider this band nonspecific. It can also be seen from the Northern blot that the larger species increased in its relative amount up to about 5 min after temperature upshift, followed by a decrease, confirming the primer extension results.

Prevention of *ftsH* induction after osmotic shock leads to growth arrest. If increased amounts of FtsH protein are really

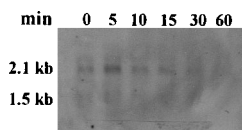

FIG. 7. Northern blot analyses. RNA was isolated from *B. subtilis* 1012 grown at 37°C in LB and shifted from 37 to 52°C. The filters were hybridized with DIG-labeled ON5, and 10 μ g of RNA was applied per lane.

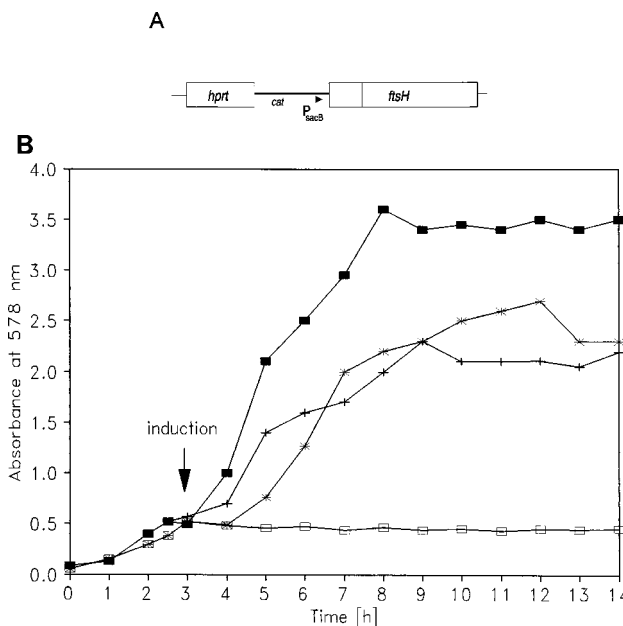

FIG. 8. Growth of wild-type strain 1012 and of strain ED10 in the absence and presence of salt. Both strains were grown in LB to the early exponential phase, and then the culture was split into two. One half was further grown under these conditions, and the other half was challenged with 1.1 M NaCl. ■, 1012, no NaCl; *, 1012, NaCl added; +, ED10, no NaCl; □, ED10, NaCl added. The time of addition of salt is indicated by the arrow.

necessary to allow growth after osmotic shock, prevention of induction of *ftsH* should lead to growth arrest. To assess this hypothesis, P_A was replaced by the sucrose-inducible promoter P_{sacB} as described under Materials and Methods, resulting in strain ED10 (Fig. 8A). In preliminary experiments, we found that ED10 could grow in the absence of inducer in LB medium. To test for growth after osmotic shock, strain ED10 was grown to the mid-exponential phase, and the culture was split into two portions. One portion was further incubated without any treatment, and the other was challenged with 1.1 M NaCl. Wild-type strain 1012 served as a control. When strain 1012 was challenged with 1.1 M NaCl, it continued growth at a reduced rate (Fig. 8B). In contrast, strain ED10 arrested growth immediately after addition of salt (Fig. 8B). Growth could be restored by addition of 2% sucrose (data not shown). These results clearly show that the growth of ED10 after osmotic shock requires increased expression of the *ftsH* gene.

DISCUSSION

The *ftsH* gene was first described in *E. coli*, where it was identified as a cell division mutation (33). Recently, it could be shown that the original mutant harbors temperature-sensitive mutations in two different genes, one in *ftsH* and the other in *ftsI*, which encodes penicillin-binding protein 3 (4); only the mutation in the latter gene impairs cell division. To avoid further confusion, *ftsH* should be renamed; we suggest *imp* (for integral membrane protease). The *ftsH* gene was cloned and sequenced and shown to encode an essential integral membrane protein of 70 kDa, with an ATPase domain (37, 38) homologous to some ATPase subunits of the eukaryotic 26S proteasome complex (28, 45). A number of *ftsH* mutants have been isolated, and there phenotypes have been studied. It turned out that in some mutants, the maturation of penicillin-binding protein 3 and of β -lactamase was impaired (4, 37),

while in others, the correct insertion of the SecY protein into the inner membrane was affected (1, 2). Furthermore, it could be shown that the *ftsH* gene is identical to *hflB* and that in *ftsH/hflB* mutants, degradation of the λ cII protein and of the alternative heat shock sigma factor σ^{32} was reduced (15, 16, 36). Quite recently, the FtsH protein was purified and shown to degrade σ^{32} in an ATP- and Zn^{2+} -dependent manner (36). Furthermore, we postulate that the FtsH protein might also be responsible for degradation of σ^S , the stationary-phase sigma factor (24), during vegetative growth. In summary, two functions are thought to be encoded by *ftsH*: an ATP- and Zn^{2+} -dependent protease and a chaperone-like function involved in the assembly of proteins into and through the cytoplasmic membrane.

The *ftsH* gene of *B. subtilis* was detected during analysis of an insertion mutant which failed to form colonies on LB plates containing 1.2 M NaCl (10). Here, we show that this failure was due to the synthesis of artificial antisense RNA interfering with the expression of the *ftsH* gene. The inability of UG1 to grow under high salt concentrations could be overcome either by deleting the promoter from which the antisense RNA originated or by extragenic suppressors (data not shown); the nature of the suppressors, which have been mapped at 17° on the *B. subtilis* chromosome, is completely unclear at present.

A detailed transcriptional analysis of the *ftsH* gene revealed that this gene is transiently induced at the level of transcription after both osmotic and temperature shock. This has been shown by primer extension and Northern blot analyses and by analysis of a transcriptional *ftsH::gus* fusion. It has to be mentioned that the *gus* reporter gene could not be used to monitor promoter activity under salt or heat stress, most probably because of rapid degradation and/or inactivation of the enzyme under these adverse conditions (data not shown).

This behavior identified *ftsH* as a general stress gene; this group of stress genes is induced by more than one stressor, in contrast to specific stress genes, which respond to only one stress factor (14). It furthermore identified *ftsH* as a member of the class III heat shock genes (34). While regulation of class I genes involves the heat shock element CIRCE, the *orf39*-encoded protein, and additional unknown factors, those of class II are controlled by the alternate sigma factor σ^B (40). Class III heat shock genes are tentatively defined as those whose expression involves neither CIRCE nor σ^B , and their regulation mechanism is completely unknown to date. Besides *ftsH*, *lon* and *clpC* are members of this class, all three of which are general stress genes (20, 29).

Our results demonstrate that the complete FtsH protein is not essential for survival of the cells under the conditions tested; the 123 C-terminal amino acid residues of the 637 total residues are dispensable. The truncated FtsH protein which is synthesized in ED1 contains the two potential transmembrane domains and the putative ATP- and Zn^{2+} -binding sites reported for *E. coli* FtsH (36, 38). Using polyclonal antibodies raised against FtsH of *E. coli*, we could show that a protein with a molecular mass of about 70 kDa, which we consider the FtsH protein, is present only in the membrane fraction, from which it could be solubilized by Sarkosyl but not by salt. These experiments carried out with the wild type and UG1 strain yielded identical results (data not shown).

In summary, our data clearly demonstrate that the amount of FtsH protein is crucial for the survival of *B. subtilis* cells under adverse conditions. After osmotic or temperature shock, the amount of *ftsH* mRNA is transiently increased two- to threefold, which is most probably followed by a comparable rise in the amount of FtsH protein. Why are increased amounts of FtsH needed after a stress? In *E. coli*, two substrates of the

FtsH protease have been identified so far, σ^{32} and λ cII (16, 36); both proteins are transcription factors. Therefore, it is tempting to speculate that in *B. subtilis*, FtsH is also involved in degradation and/or processing of transcription factors. Clarification of the biological role of FtsH awaits further extensive experimentation, including identification of the target proteins for FtsH by manipulating the amount of FtsH protein in strain ED10. Then, the protein pattern on two-dimensional gels in the presence of various amounts of FtsH will be compared with that of the wild-type strain. This should allow the identification of putative target proteins. In addition, experiments are in progress to identify the DNA sequences involved in osmotic and heat regulation.

ACKNOWLEDGMENTS

We thank U. Geisler for constructing pUG1E, T. Ogura for antibodies, and for communicating unpublished results on the *ftsH* gene of *E. coli*, and the sequence of the *ftsH* gene of *B. subtilis*. We extend our thanks to D. Nilsson for communicating unpublished data on the *L. lactis* *ftsH* gene and to A. Schulz and U. Zuber for critical reading of the manuscript.

The present work was supported by a grant from the Deutsche Forschungsgemeinschaft to W.S. (Schu 414/11-1).

REFERENCES

1. Akiyama, Y., T. Ogura, and K. Ito. 1994. Involvement of FtsH in protein assembly into and through the membrane. I. Mutations that reduce retention efficiency of a cytoplasmic reporter. *J. Biol. Chem.* **269**:5218–5224.
2. Akiyama, Y., Y. Shirai, and K. Ito. 1994. Involvement of FtsH in protein assembly into and through the membrane. II. Dominant mutations affecting FtsH functions. *J. Biol. Chem.* **269**:5225–5229.
3. Back, J. F., D. Oakenfull, and M. B. Smith. 1979. Increased thermal stability of proteins in the presence of sugars and polyols. *Biochemistry* **18**:5191–5196.
4. Begg, K. J., T. Tomoyasu, W. D. Donachie, M. Khattar, H. Niki, K. Yamanaoka, S. Hiraga, and T. Ogura. 1992. *Escherichia coli* mutant Y16 is a double mutant carrying thermosensitive *ftsH* and *ftsI* mutations. *J. Bacteriol.* **174**:2416–2417.
5. Boch, J., B. Kempf, and E. Bremer. 1994. Osmoregulation in *Bacillus subtilis*: synthesis of the osmoprotectant glycine betaine from exogenously provided choline. *J. Bacteriol.* **176**:5364–5371.
6. Chang, A. C. Y., and S. N. Cohen. 1978. Construction and characterization of amplifiable multicopy DNA cloning vehicles derived from the P15A cryptic miniplasmid. *J. Bacteriol.* **134**:1141–1156.
7. Csonka, L. N. 1989. Physiological and genetic responses of bacteria to osmotic stress. *Microbiol. Rev.* **53**:121–147.
8. Csonka, L. N., and A. D. Hanson. 1991. Prokaryotic osmoregulation: genetics and physiology. *Annu. Rev. Microbiol.* **45**:569–606.
9. Ferrari, F. A., A. Nguyen, D. Lang, and J. A. Hoch. 1983. Construction and properties of an integrable plasmid for *Bacillus subtilis*. *J. Bacteriol.* **154**:1513–1515.
10. Geisler, U., and W. Schumann. 1993. Isolation of stress mutants of *Bacillus subtilis* by a novel genetic method. *FEMS Microbiol. Lett.* **108**:251–254.
11. Gottesman, S. 1984. Bacterial regulation: global regulatory networks. *Annu. Rev. Genet.* **18**:415–441.
12. Hanahan, D. 1983. Studies on transformation of *Escherichia coli* with plasmids. *J. Mol. Biol.* **166**:557–580.
13. Hecker, M., C. Heim, U. Völker, and L. Wölfel. 1988. Induction of stress proteins by sodium chloride treatment in *Bacillus subtilis*. *Arch. Microbiol.* **150**:564–566.
14. Hecker, M., and U. Völker. 1990. General stress proteins in *Bacillus subtilis*. *FEMS Microbiol. Ecol.* **74**:197–214.
15. Herman, C., T. Ogura, T. Tomoyasu, S. Hiraga, Y. Akiyama, K. Ito, R. Thomas, R. D'Ari, and P. Bouloc. 1993. Cell growth and lambda phage development controlled by the same essential *Escherichia coli* gene, *ftsH/hflB*. *Proc. Natl. Acad. Sci. USA* **90**:10861–10865.
16. Herman, C., D. Thévenet, R. D'Ari, and P. Bouloc. 1995. Degradation of σ^{32} , the heat shock regulator in *Escherichia coli*, is governed by HflB. *Proc. Natl. Acad. Sci. USA* **92**:3516–3520.
17. Jefferson, R. A., S. M. Burgess, and D. Hirsh. 1986. β -Glucuronidase from *Escherichia coli* as a gene-fusion marker. *Proc. Natl. Acad. Sci. USA* **83**:8447–8451.
18. Karow, M., and P. Piggot. 1993. The use of *gus* and *lacZ* fusions as a double reporter system to study gene expression during *B. subtilis* sporulation, abstract P95. Abstracts of the Seventh International Conference on Bacillus, Paris, France.

19. **Kreft, J., and C. Hughes.** 1982. Cloning vectors derived from plasmids and phage of *Bacillus*. *Curr. Top. Microbiol. Immunol.* **96**:1–17.
20. **Krüger, E., U. Völker, and M. Hecker.** 1994. Stress induction of *clpC* in *Bacillus subtilis* and its involvement in stress tolerance. *J. Bacteriol.* **176**:3360–3367.
21. **Li, M., and S.-L. Wong.** 1992. Cloning and characterization of the *groESL* operon from *Bacillus subtilis*. *J. Bacteriol.* **174**:3981–3992.
22. **Lindner, C., J. Stülke, and M. Hecker.** 1994. Regulation of xylanolytic enzymes in *Bacillus subtilis*. *Microbiology* **140**:753–757.
23. **Lucht, J. M., and E. Bremer.** 1994. Adaptation of *Escherichia coli* to high osmolarity environments: osmoregulation of the high-affinity glycine betaine transport system ProU. *FEMS Microbiol. Rev.* **14**:3–20.
24. **McCann, M. P., J. P. Kidwell, and A. Matin.** 1991. The putative σ factor KatF has a central role in development of starvation-mediated general resistance in *Escherichia coli*. *J. Bacteriol.* **173**:4188–4194.
25. **Measures, J. C.** 1975. Role of amino acids in osmoregulation of non-halophilic bacteria. *Nature (London)* **257**:398–400.
26. **Nilsson, D., A. A. Lauridsen, T. Tomoyasu, and T. Ogura.** 1994. A *Lactococcus lactis* gene encodes a membrane protein with putative ATPase activity that is homologous to the essential *Escherichia coli ftsH* gene product. *Microbiology* **140**:2601–2610.
27. **Ogasawara, N., S. Nakai, and H. Yoshikawa.** 1994. Systematic sequencing of the 180 kilobase region of the *Bacillus subtilis* chromosome containing the replication origin. *DNA Res.* **1**:1–14.
28. **Rechsteiner, M., L. Hoffman, and W. Dubiel.** 1993. The multicatalytic and 26 S proteases. *J. Biol. Chem.* **268**:6065–6068.
29. **Riethdorf, S., U. Völker, U. Gerth, A. Winkler, S. Engelmann, and M. Hecker.** 1994. Cloning, nucleotide sequence, and expression of the *Bacillus subtilis lon* gene. *J. Bacteriol.* **176**:6518–6527.
30. **Saito, H., T. Shibata, and T. Ando.** 1979. Mapping of genes determining nonpermissiveness and host-specific restriction to bacteriophages in *Bacillus subtilis* Marburg. *Mol. Gen. Genet.* **170**:117–122.
31. **Sambrook, J., E. F. Fritsch, and T. Maniatis.** 1989. *Molecular cloning: a laboratory manual*, 2nd ed. Cold Spring Harbor Laboratory Press, Cold Spring Harbor, N.Y.
32. **Sanger, F., S. Nicklen, and A. R. Coulson.** 1977. DNA sequencing with chain-terminating inhibitors. *Proc. Natl. Acad. Sci. USA* **74**:5463–5467.
33. **Santos, D., and D. F. Almeida.** 1975. Isolation and characterization of a new temperature-sensitive cell division mutant of *Escherichia coli* K-12. *J. Bacteriol.* **124**:1502–1507.
34. **Schulz, A., B. Tzschaschel, and W. Schumann.** 1995. Isolation and analysis of mutants of the *dnaK* operon of *Bacillus subtilis*. *Mol. Microbiol.* **15**:421–429.
35. **Spizizen, J.** 1958. Transformation of biochemically deficient strains of *Bacillus subtilis* by deoxyribonucleate. *Proc. Natl. Acad. Sci. USA* **44**:407–408.
36. **Tomoyasu, T., J. Gamer, B. Bukau, M. Kanemori, H. Mori, A. J. Rutman, A. B. Oppenheim, T. Yura, K. Yamanaka, H. Niki, S. Hiraga, and T. Ogura.** *Escherichia coli* FtsH is a membrane-bound, ATP-dependent protease which degrades the heat-shock transcription factor σ^{32} . *EMBO J.*, in press.
37. **Tomoyasu, T., K. Yamanaka, K. Murata, T. Suzaki, P. Bouloc, A. Kato, H. Niki, S. Hiraga, and T. Ogura.** 1993. Topology and subcellular localization of FtsH protein in *Escherichia coli*. *J. Bacteriol.* **175**:1352–1357.
38. **Tomoyasu, T., T. Yuki, S. Morimura, H. Mori, K. Yamanaka, H. Niki, S. Hiraga, and T. Ogura.** 1993. The *Escherichia coli* FtsH protein is a prokaryotic member of a protein family of putative ATPases involved in membrane functions, cell cycle control, and gene expression. *J. Bacteriol.* **175**:1344–1351.
39. **van Laere, A.** 1989. Trehalose, reserve and/or stress metabolite? *FEMS Microbiol. Lett.* **63**:201–210.
40. **Völker, U., S. Engelmann, B. Maul, S. Riethdorf, A. Völker, R. Schmid, H. Mach, and M. Hecker.** 1994. Analysis of the induction of general stress proteins of *Bacillus subtilis*. *Microbiology* **140**:741–752.
41. **Völker, U., H. Mach, R. Schmid, and M. Hecker.** 1992. Stress proteins and cross-protection by heat shock and salt stress in *Bacillus subtilis*. *J. Gen. Microbiol.* **138**:2125–2135.
42. **Wetzstein, M., U. Völker, J. Dedio, S. Löbau, U. Zuber, M. Schiesswohl, C. Herget, M. Hecker, and W. Schumann.** 1992. Cloning, sequencing, and molecular analysis of the *dnaK* locus from *Bacillus subtilis*. *J. Bacteriol.* **174**:3300–3310.
43. **Whatmore, A. M., J. A. Chudek, and R. H. Reed.** 1990. The effects of osmotic upshock on the intracellular solute pools of *Bacillus subtilis*. *J. Gen. Microbiol.* **136**:2527–2535.
44. **Whatmore, A. M., and R. H. Reed.** 1990. Determination of turgor pressure of *Bacillus subtilis*: a possible role for K^+ in turgor regulation. *J. Gen. Microbiol.* **136**:705–712.
45. **Wolfe, K. H.** 1994. Similarity between putative ATP-binding sites in land plant plastid ORF2280 proteins and the FtsH/CDC48 family of ATPases. *Curr. Genet.* **25**:379–383.
46. **Yanisch-Perron, C., J. Vieira, and J. Messing.** 1985. Improved M13 phage cloning vectors and host strains: nucleotide sequences of the M13mp18 and pUC19 vectors. *Gene* **33**:103–119.
47. **Zuber, U., and W. Schumann.** 1991. Tn5*cos*: a useful tool for restriction mapping of large plasmids. *Gene* **103**:69–72.